

UNISORB®

Quantum PM™ Press Mounts

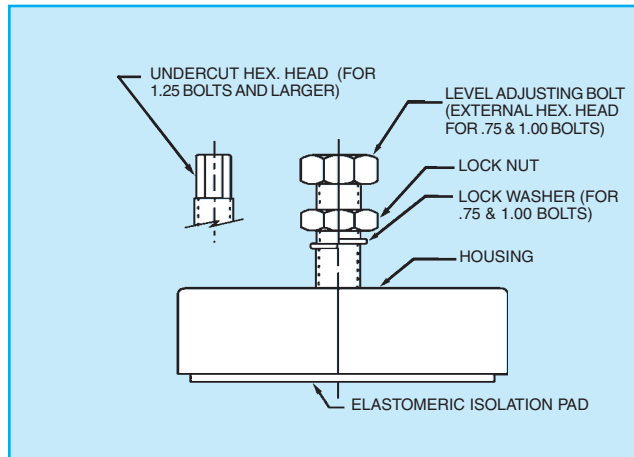
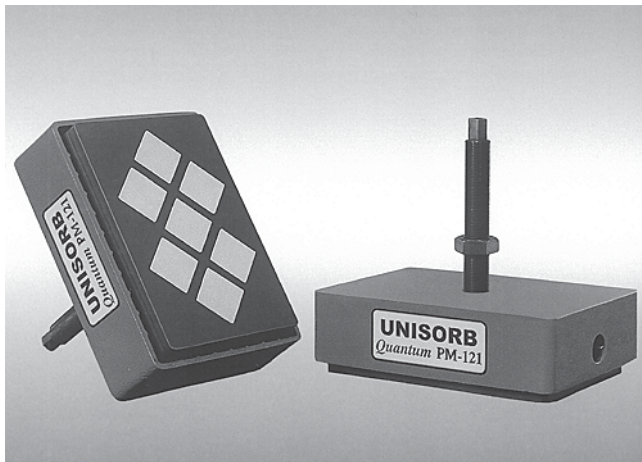

Quantum PM™ Press Mounts FOR HEAVY DUTY PRESSES

UNISORB *Quantum PM* Press Mounts for heavy duty presses eliminate the need to anchor machines to the floor. They solve impact-shock and vibration problems while providing precision leveling and alignment for trouble-free operation.

They have extra heavy-duty construction with broad bases and larger diameter leveling bolts. Designed for use with reciprocating or impact machinery, they provide close tolerance leveling adjustment. The mounts come with appropriately designed resilient isolation pads.

These self-contained leveling mounts simplify machinery installation. No drilling, lagging, adhesives, or shims are required. Accurate leveling is obtained simply by turning the leveling bolt. Once adjusted, a lock nut holds the adjustment secure. *Quantum PM* Press Mounts absorb shock and vibration while reducing noise. When properly installed, they eliminate excessive gib wear, die damage and other alignment related problems. They meet OSHA standards for anchoring machinery.

By properly utilizing UNISORB *Quantum PM* Press Mounts, excessive press motion can be eliminated and uneven weight distribution can be compensated for to prevent frame distortion, which is a major cause of early machine failure.

Quantum PM Press Mounts can usually be installed on existing shop floors. Heavy, unbroken concrete floors, preferably reinforced and resting on a good base, are desirable. Isolation features of the press mounts result in elimination of floor damage. At the same time they reduce interference of nearby equipment due to press shock and vibration.

A variety of shock pads, bolt lengths and bolt diameters are available to meet the requirements of almost any press application. Contact UNISORB Engineering for recommendations.

SPECIFICATIONS				
PRESS MOUNTS	LENGTH	WIDTH	HEIGHT (MIN.)*	ADJUSTING BOLT
PM-61	7.00	4.50	2.50	0.75 thru 1.00
PM-81	8.00	5.88	2.50	0.75 thru 1.25
PM-101	10.00	7.88	3.25	0.75 thru 1.50
PM-121	12.50	9.00	3.50	1.00 thru 1.75
PM-161	16.00	12.50	4.50	1.25 thru 2.25
PM-201	20.00	16.00	6.00	1.75 thru 3.00
PM-261	26.00	22.00	7.50	2.50 thru 4.00
PM-301	30.00	24.00	9.50	3.00 thru 4.50
PM-321	32.00	24.00	10.50	3.00 thru 5.00
PM-381	38.00	25.50	13.00	4.00 thru 6.00

All dimensions in inches. *Top of mount housing to floor.

Summary of Benefits

- Reduce installation costs.
- Easy leveling and fast, accurate alignment.
- Control shock and vibration.
- Increase die life and decrease press wear.
- Minimize expensive downtime and maintenance.
- Achieve better press productivity.
- Rugged high strength mount construction.
- All elastomeric isolation pad configurations.
- Elimination of anchor bolts.
- Reduce need for special foundations.
- Reduce operator fatigue.
- Reduce motor loads.
- Uneven floors accommodated.
- Press “walking” prevented.