



**DAKE SEMI-AUTOMATIC COLD SAW**

# **Euromatic 370S & 370S-L**

INSTRUCTIONAL MANUAL



**⚠️ WARNING!**

Read and understand all instructions and responsibilities before operating. Failure to follow safety instructions and labels could result in serious injury.

Dake Corporation  
1809 Industrial Park Dr  
Grand Haven, MI 49417

Phone: 800.937.3253

[www.dakecorp.com](http://www.dakecorp.com)

## TABLE OF CONTENTS

DAKE STANDARD LIMITED WARRANTY .....	2
RETURN & REFUND POLICY .....	4
SPECIFICATIONS.....	5
SAFETY.....	6
SET UP.....	8
TRANSPORTING AND INSTALLATION.....	8
ELECTRICAL CONNECTION .....	8
AIR SUPPLY SET UP .....	9
LOADING/UNLOADING TABLES .....	9
HEAD CHANGE .....	9
BLADE INSTALLATION .....	9
CHOOSING A BLADE.....	11
SPEEDS AND FEEDS .....	12
SETTING HEAD PARAMETERS .....	13
GIB BLOCK ADJUSTMENT .....	14
VISE ADJUSTMENTS.....	15
MITER CUTTING & SQUARING.....	16
TUBING FIXTURES EXAMPLES.....	17
OPERATION .....	17
CONTROLS .....	19
STARTING THE SAW .....	19
MAINTENANCE .....	20
TROUBLESHOOTING .....	23
ELECTRICAL COMPONENTS.....	24
PNEUMATIC SYSTEM SCHEMATICS.....	25
EXPLODED VIEWS AND PART LISTS .....	26
ORDERING INFORMATION .....	35
DEACTIVATING THE MACHINE .....	36
DISMANTLING THE MACHINE .....	36



## DAKE STANDARD LIMITED WARRANTY

### *Finished Machines*

Dake warrants to the original purchaser the finished machine manufactured or distributed by it to be free from defects in material and workmanship under normal use and service within 1 year (12 months) from the delivery date to the end user.

### *Parts*

Dake warrants to the original purchaser the component part manufactured or distributed by it to be free from defects in material and workmanship under normal use and service within 30 days from the delivery date to the end user.

The standard limited warranty includes the replacement of the defective component part at no cost to the end user.

### *Sale of Service (Repairs)*

Dake warrants to the original purchaser the component part repaired by Dake Corporation at the manufacturing facility to be free from defects in material and workmanship under normal use and service within 90 days from the return date to the end user, as it pertains to the repair work completed. The standard limited warranty includes repair of the defective component part, at no cost to the end user.

## Warranty Process

Subject to the conditions hereinafter set forth, the manufacturer will repair or replace any portion of the product that proves defective in materials or workmanship. The manufacturer retains the sole right and option, after inspection, to determine whether to repair or replace defective equipment, parts or components. The manufacturer will assume ownership of any defective parts replaced under this warranty.

All requested warranty claims must be communicated to the distributor or representative responsible for the sale. Once communication has been initiated, Dake Customer Service must be contacted for approval:

Phone: (800) 937-3253

Email: [customerservice@dakecorp.com](mailto:customerservice@dakecorp.com)

When contacting Dake, please have the following information readily available:

- Model #
- Serial #
- Sales Order #

Purchasers who notify Dake within the warranty period will be issued a Case number and/or a Return Material Authorization (RMA) number. If the item is to be returned per Dake's request, the RMA number must be clearly written on the exterior packaging. Any item shipped to Dake without an RMA will not be processed.

### **Warranty Exceptions:**

The following conditions are not applicable to the standard limited warranty:

- (a) Part installation or machine service was not completed by a certified professional, and is not in accordance with applicable local codes, ordinances and good trade practices.
- (b) Defects or malfunctions resulting from improper installation or failure to operate or maintain the unit in accordance with the printed instructions provided.
- (c) Defects or malfunctions resulting from abuse, accident, neglect or damage outside of prepaid freight terms.
- (d) Normal maintenance service or preventative maintenance, and the parts used in connection with such service.
- (e) Units and parts which have been altered or repaired, other than by the manufacturer or as specifically authorized by the manufacturer.
- (f) Alterations made to the machine that were not previously approved by the manufacturer, or that are used for purposes other than the original design of the machine.



## RETURN & REFUND POLICY

Thank you for purchasing from Dake! If you are not entirely satisfied with your purchase, we are here to help.

### Returns

All Dake manufactured / distributed machines, parts and couplings include a 30-day return option. These policies are valid from the date of final shipment to the end user.

To be eligible for a return, the item must be unused and in the same condition as received.

All requested warranty claims must be communicated to the distributor or representative responsible for the sale. Once communication has been initiated, Dake Customer Service must be contacted for approval:

Phone: (800) 937-3253

Email: [customerservice@dakecorp.com](mailto:customerservice@dakecorp.com)

Once the return request has been approved by Customer Service, a representative will supply a Return Material Authorization (RMA) number. The returned item must have the provided RMA number clearly marked on the outside packaging. Any item received without an RMA number clearly visible on the packaging will not be processed.

An RMA number can only be provided by the Dake Customer Service team and must be obtained prior to the return shipment.

### Refunds

Once the item has been received and inspected for damages, a representative will notify the requestor referencing the provided RMA number.

If the return is approved, a refund will be issued to the original method of payment, less a 20% restocking fee. The restocking fee may be waived if an order is placed at the time of return with like-value merchandise.





Transportation costs are the responsibility of the end user and will not be credited upon return approval.

Any item that is returned after the initial 30 days or has excessive/obvious use will not be considered for a full refund.

## SPECIFICATIONS

<b>Model</b>	<b>Euromatic 370S</b>	<b>Euromatic 350S-L</b>
<b>Number</b>	976200-2	976202-2
<b>Voltage</b>	220V/440V (440 with transformer)	220V/440V (440 with transformer)
<b>Phase</b>	3-Phase	3-Phase
<b>Cutting Ability</b>	Ferrous, Non-Ferrous, Plastic	Non-Ferrous, Plastic
<b>Horsepower</b>	3.5/4.5 HP	3.5/4.5 HP
<b>Speeds</b>	25/50 RPM	1,500/3,000 RPM
<b>Max blade diameter</b>	14-1/2"	14-1/2"
<b>Maximum vise opening</b>	8-3/4"	8-3/4"
<b>Slotting</b>	Yes	No
<b>Maximum angle</b>	45° / 90°, left / right	45° left
<b>Weight</b>	1,360 lbs	1,360 lbs
<b>Work Height</b>	35"	35"
<b>Height</b>	73"	73"
<b>Base</b>	28" x 39"	28" x 39"

## CUTTING CAPACITY

				
<b>90°</b>	4-1/4"	5-1/16"	4-1/4"	4" x 7"
<b>45°</b>	3-5/8"	5"	3-7/8"	4" x 6"

In the space provided record the serial number and model number of the machine. If contacting Dake this information must be provided to assist in identifying the specific machine.

<b>Serial No.</b>	
<b>Model No.</b>	
<b>Date Purchased:</b>	

## SAFETY

 **This is the safety alert symbol.** When you see this symbol on your machine be alert to the potential for personal injury.

Carefully read all safety messages in these instructions and on your machine safety signs. Keep safety labels in good condition. Replace missing or damaged labels.

Employer is responsible to perform a hazard/PPE assessment before work activity.

**⚠ DANGER**  
High voltage.  
Can cause severe  
injury or death.  
Service by  
authorized  
personnel only.  
Use lockout.



**⚠ PELIGRO ⚠**  
Alta tensión.  
Puede provocar  
lesiones severas o la  
muerte.  
Para reparaciones,  
emplee personal  
autorizado solamente.  
Use cierre eléctrico.

Label Part No.  
84395

**SAFETY  
INSTRUCTIONS**

**LOCKOUT PROCEDURE**

1. Announce lockout to other employees.
2. Turn power off at main panel.
3. Lockout power in off position.
4. Put key in pocket.
5. Clear machine of all personnel.
6. Test lockout by hitting run button.
7. Block, chain or release stored energy sources.
8. Clear machine of personnel before restarting machine.

Label Part No.  
76462

**SAFETY  
INSTRUCTIONS**

1. Read the instruction manual thoroughly before operating this machine.
2. Wear safety glasses.
3. Wear gloves only when handling material or replacing blade.
4. Never wear gloves while blade is rotating.
5. Do not perform cutting operations which exceed machine capacity.
6. Do not force machine to stall blade or breakage might occur.
7. Clamp workpiece securely.
8. Always use stock stands on both sides of saw blade to support material.
9. Use only blades to correct specification for the material being cut.
10. Keep floor around machine clean and free from chips, scraps, oil, and coolant.
11. Always lockout electrical power before performing maintenance, servicing, or changing blades.

Label Part No.  
84605

**⚠ WARNING**



Never reach into the point of operation.  
Do not operate without all guards in place.

Label Part No.  
82199



**WARNING:** This product contains Nickel, a chemical known to the State of California to cause cancer. For more information go to [www.P65Warnings.ca.gov](http://www.P65Warnings.ca.gov)

**⚠ WARNING**





Establish solid footing to prevent falls.  
Keep hand away from point of operation.  
Read instructions.  
Guard workpiece to prevent projectiles from reaching operator.  
Wear eye protection.

Label Part No.  
300168

### **Additional Safety Warnings:**

- This machine is intended to be operated by one person. This person should be conscious of the machine movement not only for themselves but also for persons on the immediate area of the machine.
- Never have several objects in your hands at once and keeps hands as clean as possible.
- This machine has been built to comply with national accident prevention regulations. Improper use and/or tampering with the safety devices will relieve the manufacturer of all responsibility.
- All internal and/or internal operation, maintenance or repairs, must be performed in a well-lit area or where there is sufficient light from extra sources so as to avoid the risk id even light accidents.
- It is forbidden to disconnect the “man present” device, known more correctly as the “safety switch with hold-down action”.
- Check that the voltage indicated on the plate, normally fixed to the machine motor, is the same as the line voltage.
- Check the efficiency of your electric supply making sure the machine has its own grounded circuit.
- Do not operation machine without safety guards or with the electrical panel cover removed.
- Then the tool head is in rest position (raised), the toothed disk must be stationary.
- Always disconnect the machine from the power socket before changing the disk or carrying out any maintenance job, even in the case of abnormal machine operation.
- Do not operate this machine without the handle and/or handle switch disconnected.
- Always wear OSHA approved safety glasses when operating this machine.
- Never put your hands or arms into the cutting area while the machine is operating.
- Do not shift or move machine while the machine is in operation.
- Do not wear loose clothing with sleeves that are too long, gloves, bracelets, rings, watches, chains, or any other object that could get caught in the machine during operation; tie back long hair.
- Keep the machine bed free from tools or any object, while the machine is in operation.



## SET UP

### TRANSPORTING AND INSTALLATION

1. Remove box or shrink wrap. Carefully inspect the machine for any physical damage.
2. Remove metal banding that holds machine to the skid.  **WARNING: Banding may be sharp and may cause injury.**
3. Check that all standard parts and optional accessories are included with machine. Some accessories may be located in chip drawer or behind the access door.
  - a. Each machine should include one blade, one gallon of coolant, tool kit, owner's manual, and saw pitch calculator.
4. Remove machine from skid. If using an overhead hoist, place a sling around the gear box and the sling around the feeder portion on the machine. **DO NOT PLACE SLING AROUND THE FEED CYLINDER.** The sling is to stabilize the machine while lifting and is not intended for lifting a large load.
  - a. Always take proper precautions when lifting the machine. If the machine slips or moves while lifting injury may occur. If a forklift is used to move the machine, make sure the weight is distributed evenly and the forks are all the way through before lifting.
5. Set the machine in a location where it will be in operation, on a level surface. Make sure that the saw is located where it will not interfere with its surroundings. The machine must not be in a location in unsafe working conditions may exist.
6. Discard packing materials in a safe manner. Make sure all accessories and literature has been removed.
7. Clean off all surfaces that have been greased or coated with rust inhibitor.
8. Making sure that the machine is placed on a flat surface, adjust the leveling bolts located in the foot flange of the machine base. Adjust the machine so that it does not rock from floor irregularities.

### ELECTRICAL CONNECTION

 All electrical connections should only be made by a qualified electrician. Before turning on the power, check that all the electrical components are in place. They may have come loose in shipping. If any questions arise please call DAKE or consult your electrician.

The main power source must supply the machine with a separate breaker of proper amperage.

For a 220-volt machine a 20-amp service is recommended.

For a 440-volt machine a 16-amp service is recommended (transformer required).

Machines are rated at +/-10%. The wires are connected to the terminal block inside the control cabinet.

## **AIR SUPPLY SET UP**

Locate the air regulator on the rear of the vertical column and connect the air supply.

1. Once all the air fittings are secure, turn the air supply on to the machine. The gauge should read 90 PSI.
2. If the reading is more or less, adjust the regulator to 90 PSI. If the reading is more or less adjust the regulator to 90 PSI

**Incoming air from the air compressor must be clean and dry. Use all precautions and water traps as necessary.**

## **LOADING/UNLOADING TABLES**

After electric and air supply is setup if loading or unloading tables were ordered install them now.

**Make sure the tables are level and precise in alignment with the feeder unit.**

## **HEAD CHANGE**

If both the ferrous and non-ferrous heads were purchased and you need to change out the head please contact DAKE for instructions.

## **BLADE INSTALLATION**

**WARNING**  Before performing the following operations, the electrical supply must be **LOCKED OUT** and always wear gloves when installing a new blade.

### **Blade Installation for a Ferrous Head:**

1. Open the clear protective cover and magnetically latched blade guard.
2. Remove the spindle flange bolt using the socket wrench provided.
3. Remove the blade flange and wipe the blade surface of the flange and spindle clean.
4. Carefully slide the blade up through the coolant distribution tubes. Be careful not to bend the tubes.
  - a. Make sure teeth are facing the correct direction for counter-clockwise rotation.
5. With a rolling motion of the blade counter-clockwise, push against the chip brush and slide blade over the spindle shoulder.
6. Rotate the blade on the shoulder to align the two large drive pin holes.
7. Insert the flange pins through the drive pin holes and insert bolt, hand tighten at this point.

8. **Backlash must be removed from the blade.** This is done by pushing against rotation with a gloved hand, until it bottoms out on the drive pins.
  - a. **⚠ Failure to remove backlash may result in blade breakage and serious injury.**
9. While holding the blade against the pins tighten the spindle bolt securely.
10. Close blade cover and replace clear protective cover.

### **Blade Installation for a Non-Ferrous Head:**

**WARNING ⚠ NEVER ATTEMPT TO CUT STEEL OR FERROUS MATERIALS WITH A NON-FERROUS HEAD INSTALLED. IT MAY CAUSE SERIOUS INJURY OR FIRE.**

1. Open the clear protective cover and magnetically latched blade guard.
2. Clean spindle and flange faces, so there are no chips on the faces.
3. Remove part “b” using wrench “d” on shaft “c”.
4. Use hex wrench “e” to remove bolt “f”, which has left-handed threads.
5. Install blade on the spindle shaft shoulder, so the teeth are facing downwards, for clockwise rotation.
6. Install blade flange. Make sure no to hit any machine parts with the carbide tips, this this may affect the blade performance.
7. Screw the spindle bolt on by hand.
8. Holding the spindle shaft with the wrench, tighten the bolt securely.
9. Close and tighten blade cover and close clear protective cover.

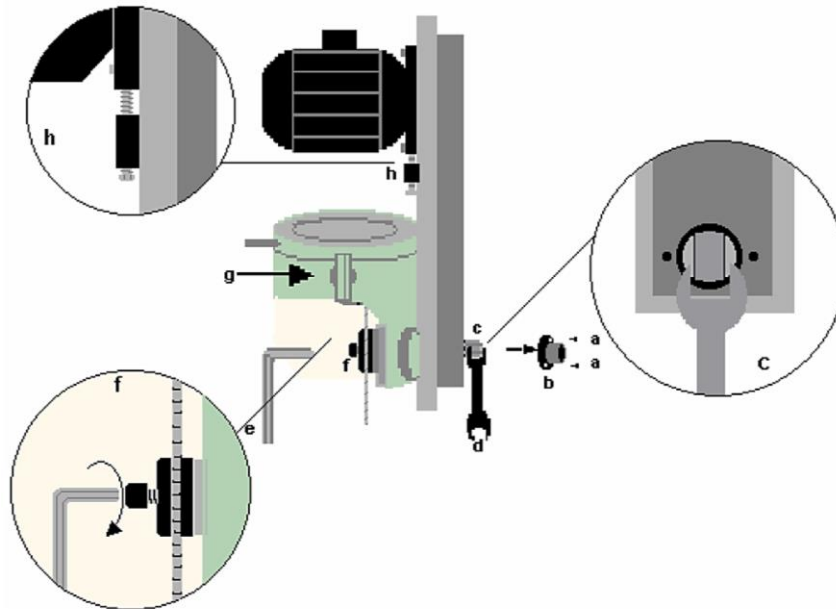

Note: The blade pins may have been removed from your blade flange to allow easier blade sizing and safety. **If you install the pins for a carbide or HSS blade backlash must be removed from the blade while installing, however it is not recommended to reinstall these pins.** See ferrous blade installation for backlash removal.

## CHOOSING A BLADE

The saw will come with a “DAKE Saw Pitch Calculator” to assist in blade selection.

**WARNING**  **Never use a blade that is cracked, dull, or missing teeth.**

First the pitch of the teeth must be chosen, suitable for the material to be cut, according to these criteria:

- Parts with a thin and/or variable section such as profiles, pipes, and plates, need fine toothing, so the number of teeth used simulations cut. The larger the part the coarser toothing is needed.
- Larger parts require a coarser toothed blade.
- An improper pitch or grind will sacrifice the quality of the cut, safety, and blade life.
- There are many different grinds and coatings available for blades.
- Blade thickness can affect the way the blade will cut, for thinner materials a thinner blade is recommended.
- When miter cutting the next larger pitch blade may be required.
- Each high-speed blade can be reground up to approximately 20 times if properly done.
- Always have blades reground by a qualified professional. Always use blade with proper pin hole spacing if applicable.
- If still unsure what blade to purchase/use contact your blade provider or DAKE.

### For ferrous cutting:

The larger or harder the material the slower the speed needs to be. The thinner or softer the material the faster the speed needs to be.

Example:	3” Solid cold rolled	25 RPM
	2” Solid stainless	25 RPM
	2” x 1/8” wall tubing	50 RPM
	2” Solid aluminum	50 RPM

### **For non-ferrous cutting head:**

Same rules apply as with the ferrous cutting head. The selection of tooth configurations is more limited with carbide.

Solid material from 2" - 4": 14" x 60 tooth blade is recommended.

Solid material from 1" - 2": 4" x 84 tooth blade is recommended.

Material less than 1": 14" x 100 tooth blade is recommended.

Large extrusion with relief: 84-tooth blade may be used.

Any thin wall tubing or small extrusions with relief: 100-tooth blade.

- There are different types of grinds for carbide, positive pitch and negative pitch. Positive pitch blade for more aggressive cutting and negative pitch for thinner materials.
- For some applications a high-speed steel blade is available for the non-ferrous cutting head and normally run on the 1500 RPM setting.
- Precision ground carbide blades may be purchased for a superior finish.
- 3000 RPM is the normal cutting speed for non-ferrous material with a carbide blade.
- The non-ferrous blade will not normally throw a curled chip even if speeds and feeds are correct.

### **SPEEDS AND FEEDS**

The best way to determine correct blade feed and speed is by the sound of the cut and chip appearance.

Curly, shiny, cool chips: proper blade feed and speed.

Bent, discolored and/or hot chips: blade feed may be fast or slow.

Powdery or splintered chips: blade feed may be too fast or slow, incorrect blade may be in use.

## SETTING HEAD PARAMETERS

This is a dependable method of reducing “dead air” cutting. The picture above illustrated the four basic parts of the head positioning system.

- A: Lower limit adjustable cam block.
- B: Machined T-slot way that the cam moves vertically in.
- C: Upper head limit adjustable cam block.
- D: Limit switch that controls the lower setting. When the switch is activated the blade stops and the head returned to the upper setting.
- E: Upper limit switch, this controls the head

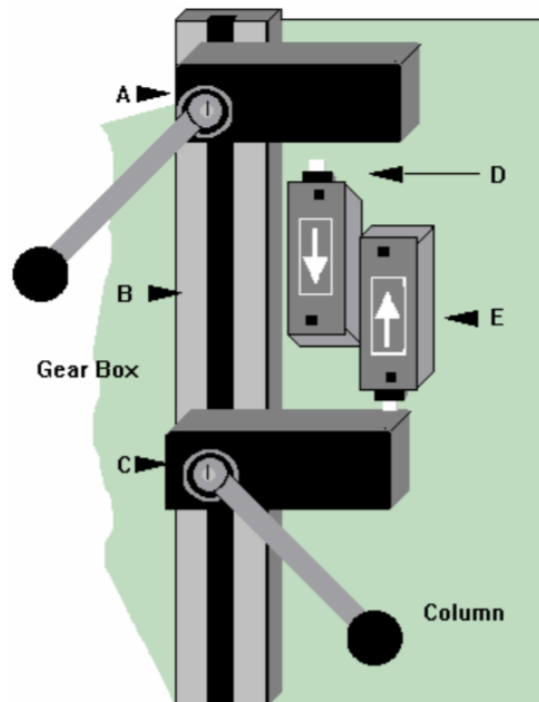

**WARNING** ⚠ **NEVER MAKE THESE ADJUSTMENTS WITH THE BLADE ROTATING. NEVER DEPRESS THE LIMIT SWITCHES WITH YOUR FINGER, YOUR FINGER COULD BE CRUSHED OR AMPUTATED BETWEEN THE LIMIT SWITCH AND CAM BLOCK.**

1. To set the parameters move the cams to the extreme positions and tightened down. (The top cam to the highest position and lower cam to the lowest position.)
2. Turn the speed selector to “0”, or “OFF”.
3. Place material in the main vise and up to the blade path, move the head feed control valve to “0”. **Do not place material under the blade path.**
  - a. Make sure the emergency button is not engaged.
4. Press the yellow button and slowly open the feed valve. As the head descended downward toward the material, close the head feed flow control valve to stop the head just above the material. **Never have the blade adjusted closer than 1/2" to the material to allow proper clearance.**

- After stopping the head, loosen the upper head setting cam (the cam block on bottom), and raise the cam up to where it touches the limit switch without depressing the limit switch button. Securely tighten this cam down. (The power of the head feed cylinder will move this limit if the cam is not securely tightened.)

**Note: Never lock the cam locks half-on or half off the T-slot.**

- Adjust the lower head setting cam (top cam block) to the highest position. Then open the feed flow control valve and let the head descend just past the lowest point of the material, then close the valve. Now slide the lower parameter cam setting block (top cam block) down to the limit switch. Holding the cam tight activate the limit switch button. This must be done before the head returns to the upper position, make sure it is securely tightened.

## GIB BLOCK ADJUSTMENT

- A: Hardened Ways  
B: Gib Plate (3 pieces)  
C: Gib Blocks (6 pieces)  
D: Gib Block Adjusting Bolts  
E: Vertical Column

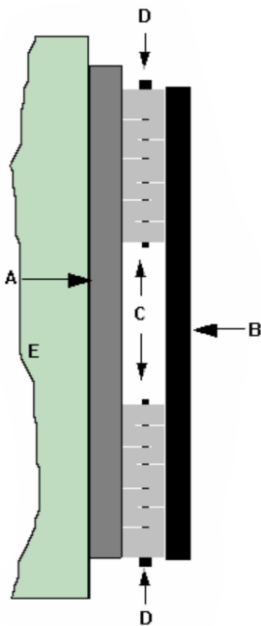

- Remove rear cover plate from vertical column.
- Locate the six cast iron gib blocks mounted to the three gib block plates, two located on the back of the column and the last located on the left side of the column.
- Tighten the gibs by turning the adjusting bolts clockwise, half a turn at a time to compress gib blocks.
- Tighten all blocks equally until the head travels smoothly on the column.
- To square the cutting head, loosen and tighten block accordingly.

**Note: Keep ways oiled.**

## WISE ADJUSTMENTS

Proper vise set up and adjustments are very important for quality and safe cutting.

**WARNING** ⚠️ **KEEP FINGERS AWAY FROM THE VISE OPENING, IT MAY CAUSE PERSONAL INJURY.**

**WARNING** ⚠️ **ALWAYS CLAMP PARTS PROPERLY, THE BLADE CAN THROW LOOSE PIECES FROM THE MACHINE AND CAUSE INJURY.**

**WARNING** ⚠️ **PROPERLY ADJUST ALL VISES BEFORE CUTTING. MAKE SURE THE BLADE WILL NOT STRIKE ANY STEEL PARTS OF THE MACHINE. IF DEEP MITER CUTS ARE BEING MADE, LOWER WEAR PLATES MAY NEED TO BE REPLACED WITH ALUMINUM PLATES OR REMOVED AND A CLEARANCE CUT MADE INTO THE PLATES WITH A STEEL CUTTING SAW.**

1. With the vise in the open position, insert the material and turn the handwheel until the vise jaw is 1/16" to 1/8" away from the material.
2. Push the emergency stop button to activate the vise to see if the material is properly clamped.
  - a. To deactivate the vise, turn the emergency stop button to the right.

**Note:** The main vise can be moved left and right via the T-slots. This allows to clamp close to the blade, even when making miter cuts.

3. Adjust the anti-burr arm to a setting the clamp the material in rear vise jaw. This is done by loosening the bolt that holds the anti-burr arm bracket.

**Note:** The anti-burr arm is not designated for clamping, but to hold the piece in place from moving when the blade exits the cut. The anti-burr arm may need to be removed for some angled cuts.

Below is the optimum cutting position for a non-ferrous head:

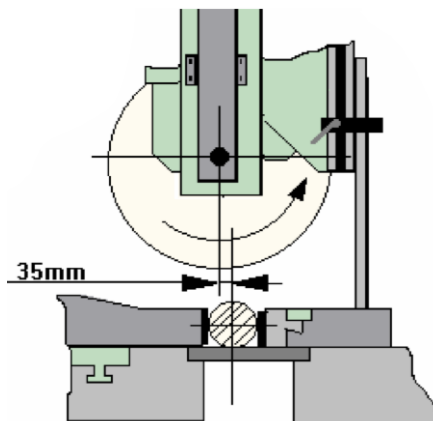

- The optimum cutting position as shown above will put the center line of the blade 35mm in from of the center line of the material being cut.



- To maintain this cutting position adjustments to the rear vise will be necessary.
- This adjustment is made by loosening the rear vise and sliding the T-slots forward or back to reach this optimal position.
- The adjustment is necessary when a different size blade is used on the machine. With a different blade size, the centerline of the blade will change.
- By adjusting the rear vise you may also achieve a more or less aggressive cut position.

## **MITER CUTTING & SQUARING**

The 370 S has a scale scribed into the front of the rotating portion of the cutting head (0 to 60°). On the stationary portion of the cutting head casting is a scribed line. Any angle can be set by loosening the lock handle. This handle is located front and center of the cutting head.

Loosen the locking handle, this handle can be pulled and repositioned to clear the coolant tube. Loosen this handle and position it in an upwards position so it will not hit the casting while you rotate the head. With the handle loose, turn the cutting head using the rotation handle to the angle needed. Lock down tightly when angle is set.

### **WARNING HEAD MUST BE LOCKED IN POSITION**

There are preset stops at 90° and 45°. Remove the positive stop on the left-hand side of the cutting head to go beyond 45°. This will allow it to miter in both directions and allow placement of the head for slotting.

The saw can be squared up on the horizontal plane with two adjusting bolts on the positive stop block located on the left side of the cutting head. Loosen the lock nuts and adjust the stop bolts in or out against the positive pin stops to achieve squareness.

Adjust the main vise as close to the blade as possible, in the T-slots, without interfering with the cutting.

Some applications may require repositioning of the rear vise jaws, for proper clamping. This can be done by loosening the locking bolts on the jaw and moving closer to the blade.

Some miter cuts will require removal of the anti-burr arm. Vises may need to clamp tighter for mitering some materials. While cutting on an angle the part may be pulled toward the blade if the vises are too loose. When mitering, the next largest tooth size may be required because the cross section that is being cut is increasing and may require a coarser blade.

## TUBING FIXTURES EXAMPLES

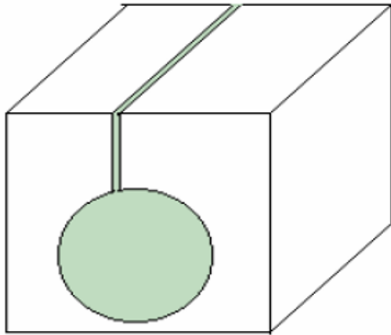

Single tube block:  
Bore hole the diameter  
of tube, then slit.

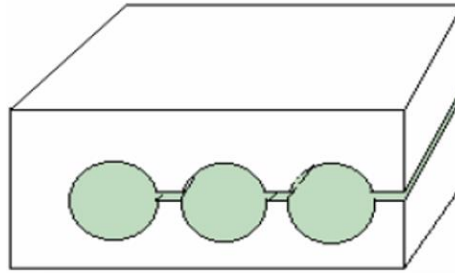

Multiple tube block

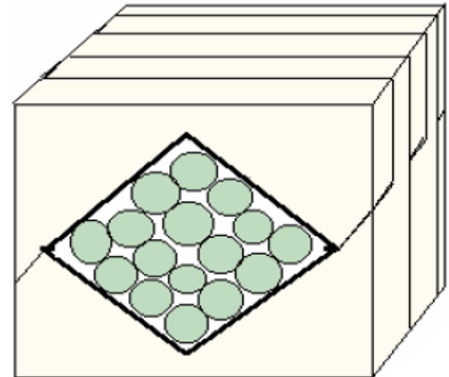

Combined jaws (3 pieces per kit.  
1 feeder, 1 outboard, 1 inboard)  
will clamp up to 2-1/2 in<sup>2</sup>

## OPERATION

### Operating Tips:

- Blade Tips
  - Always inspect blade before installing on machine, if questionable do not use.
  - Check gullets on blade. Check teeth and surfaces of blade. If a chip is packed in the gullets do not use, a blade in this condition will “thump” each time the blade passes through the material and could cause breakage. This condition is normally evident when an over feeding conditions exist or when a blade is too fine for the material.
  - The side of the blade should not have any type of smear or build up on it. This happens when the cut is too slow.
  - Always remove backlash from ferrous head blades.
  - Always cut with coolant if possible. It is better to use too much coolant that not enough and is better to mix your coolant on the heavy side. This way plain water can be added to bring it up to level. Plus, the rust inhibitors have a better chance to work.
  - Select your blade properly. Using your blade calculator or contacting your blade provider.
  - If you are cutting tubing and are having a problem with chatter, go to a finer tooth. Rule of thumb if a blade change is required, to go with a finer tooth for tubing, and a heavier tooth for solids.

- Keep your blades sharp. Do not keep cutting on a dull blade. This may damage the blade and your material as well as put stress on the machine.
- Always have your blade sharpened by a qualified professional. Contact DAKE if in need of a referral to a reputable business.
- Never use a blade smaller or larger than stated in the specification and always use a blade with correct pin hole spacing if applicable.
- Cutting Tips
  - Watch the chip to know if the correct speed and feed is being used for the material being cut. Refer to “Speeds and Feeds” section of this manual as well as making sure there is sufficient coolant flow.
  - If the blade bucks or chatters check your blade conditions described above.
  - On material you have not cut before, make some trial cuts. Always start off at a low speed, increase it from here until it sounds like it is cutting smoothly and cutting at its fastest rate.
- Operational Tips:
  - All doors and covers must be closed before machine will operate.
  - Always set vises correctly.
  - If material is shaped in a way that it cannot be safely clamped in the vises a fixture may need to be used.
  - If bundle cutting round stock without comb jaws tack weld the end of the bundle to prevent parts from spinning.
  - Fine wall tube may be crushed when clamping. A block with a hole bored through it then slit length wise will hold the tube without crushing it. See “Tubing Fixtures” in this manual for examples.

## CONTROLS

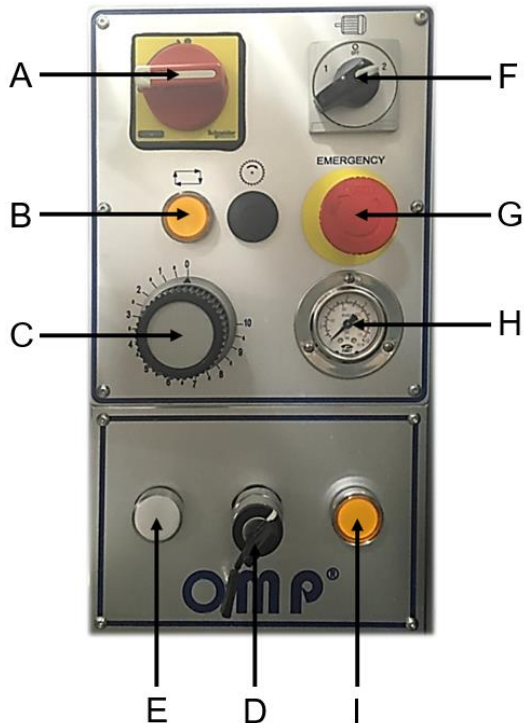

- A: Power Switch
- B: Cycle Start Button
- C: Head Feed Flow Control
- D: Security Key Switch
- E: Power On Indicator Light
- F: Motor Speed Switch
- G: E-Stop Button
- H: Air Pressure Gauge
- I: Security Interrupted Indicator Light

## STARTING THE SAW

Once the machine is set up and coolant is added the machine can now be operated.

**⚠ IF AT ANYTIME BLADE ROTATION NEEDS TO BE STOPPED ABRUPTLY PRESS THE EMERGENCY STOP BUTTON.**

1. Ensure that the head parameters are set, see “Setting Head Parameters” in this manual and the material is properly secured in the vises, see “Vise Adjustments” in this manual if assistance is needed.
2. Close the safety guard and turn power on to the machine.
3. Close the head feed control knob to the “0” setting.
4. Ensure that the head of the machine is in the up position, making contact with the upper limit switch.
5. Select a speed with the motor speed switch.
  - a. Setting “1” is the lowest RPM setting, and “2” is the highest RPM setting.
  - b. **WARNING ⚠ NEVER ADJUST THE BLADE SPEED OF THE SAW IN THE MIDDLE OF A CUTTING OPERATION.**
6. Press the “Cycle Start Button”, this will start blade rotation and coolant flow.
  - a. Check to make sure that the blade is rotating in the correct direction: counter-clockwise for a ferrous head and clockwise for non-ferrous.
  - b. The valve above to the right of the blade guard controls the coolant flow and can be adjusted.

7. Use the head feed control knob to adjust the decent of the blade. When the blade finishes the cut and makes contact with the lower limit switch blade rotation will stop and the head will return to the upper position.
8. From here the material can be adjusted to make another cut, only the “start cycle button” needs to be pressed to make another cut.

## MAINTENANCE

### MAINTENANCE FOR FERROUS HEAD:

- Gear Box: Maintain safe oil level of oil. Oil should be visible through the sight glass on the right side of the gear box when machine the is running.
  - **Note:** Oil will appear foamy during machine operation. When running at high speed oil may weep from the filler cap, this is normal and will subside once machine has expelled out the excess oil in the gear box.
- Air Oiler: Located on the air regulator. Air must be dry and clean. Use appropriate measures to ensure this before air enters the machine.
- Head Feed Cylinder: The oil reservoir is mounted on to the cylinder. The reservoir is clear, and you can visibly inspect the level. When oil is approximately the depth of 1/4", oil must be added. To fill the reservoir remove the brass cap on top and add oil into the reservoir until full and cause the cycle head to bleed. **WARNING ⚠ LOCK OUT AIR SUPPLY TO THE MACHINE BEFORE REMOVING THE OIL RESERVOIR PLUG.**
- Chip Drawer: Located behind the front door access door, this drawer pulls out for easy cleaning.
- Coolant: This pan is located under the chip drawer. The coolant should be kept clean. When coolant needs changing, remove the drain plug from the pan.
- Way Oiler: This reservoir is on the back of the column. This reservoir should be kept topped off. At the beginning of each shift, this should be pumped twice to maintain good lubrication for the ways.
- Gib Blocks: This acts an adjustable guide for the gear box.
- Vise Gib: Can be adjusted by loosening the lock nuts and turning the set screws equally. This should be done whenever the vise shifts left or right when clamping.
- Chip Brush: Replace as needed.
- Excessive Backlash: This can be reduced by removing the spindle shaft cover plate on the lower righthand side of the gear box. Using the set screws in plate, loosen the mounting bolt and tighten the set screws. Tightening these set screws will pull the plate away from the gear box and allow removal of the plate. With the plate removed tighten the spindle nut and replace plate in reverse order. Proper backlash will be approximately 1/16" to 1/8" play in the spindle with the blade on the spindle.

### Daily Maintenance

- Check and/or add oil to head feed cylinder as needed.
- Empty chip drawer.
- Add 2 pumps of oil to way oilers.

### Weekly Maintenance

- Check and add coolant as needed.
- Check and add oil for way oiler.

### Monthly Maintenance

- Check and add oil to the air regulator oiler as needed.
- Change out coolant.
- Check gibs and vise gibs.

### 100 Hour Maintenance

- Change gear box oil after first 100 hours of operation.

### 6 Month Maintenance

- Change gear box oil.
- Adjust gibs and vise gibs if needed.

## **MAINTENANCE FOR NON-FERROUS HEAD**

- **Gear Box:** The gear box does not require any oil. The horizontal spindle has zerk fittings provided for lubrication. The spindle should be greased with a high quality, high temperature grease.
- **Air Oiler:** Located in the air regulator must be dry and clean. Use appropriate measures to ensure this before air enters the machine.
- **Head Feed Cylinder:** The oil reservoir is mounted into the cylinder. The reservoir is clear, and you can visibly inspect the oil level. When oil is approximately 1/4" in depth more oil must be added.
  - To fill reservoir, remove the brass cap on top and add oil in to the reservoir until full cycle head begins to bleed.
- **Chip Drawer:** Located behind the front access door, this drawer pulls out for easy cleaning. If a chip collection unit has been installed to the back of the machine, it should be emptied regularly. Chips will also build up within the vertical column which will need to be cleared.
- **Coolant Pan:** Located under chip drawer. The coolant should be kept clean. When coolant needs changing, remove the drain plug from the pan.

- Way Oiler: This reservoir is on the back of the column and needs to be kept full. At the beginning of each shift, this should be pumped twice to maintain good lubrication for the ways.
- Gib Blocks: This acts as an adjustable guide for the gear box.
- Vise Gib Block: Can be adjusted by loosening the lock nuts and turning the set screws equally. This should be done whenever the vise shifts left or right when clamping.
- Belt Tensioning should be done as needed.
  1. Loosen the four motor mounting bolts.
  2. Using the adjusting bolt threaded in to the block on the motor panel adjust as needed.
  3. Tighten motor mounting bolts securely.

**Note:** If there is no adjustment left in the threads the belt may be stretched and in need of replacement. Belt tension should have approximately 1/4"-3/8" deflection. On occasion if adjustment is not possible loosen the motor mounting bolt and reposition the motor and try adjustment.

#### Daily Maintenance:

- Clean chips out of the vertical column.
- Check and/or add oil to head feed cylinder as needed.
- Empty chip drawer.
- Add 2 pumps of oil to way oilers.

#### Weekly Maintenance:

- Add grease to spindle as needed.
- Check and add coolant as needed.
- Check and add oil for way oiler.

#### Monthly Maintenance:

- Check and add oil to the air regulator oiler as needed.
- Change out coolant.
- Check gibs and vise gibs.

#### 6 Month Maintenance:

- Adjust gibs and vise gibs if needed

## TROUBLESHOOTING

<b>SYMPTOM</b>	<b>CAUSE</b>	<b>SOLUTION</b>
Blade chatter while cutting	Blade pitch is incorrect, blade gullets are packed	Replace blade, regrind, clean gullets
Part moves while cutting	Part not clamped properly, rear vise	Re-clamp or fixture as needed
Part has hanging burr	Part distorted while clamped, anti-burr vise	Adjust anti-burr arm or outboard vise
Part has burr on exit of cut	Lack of support on short pieces	Add solid wear plate to support part
Rough or scored finish	Dull blade, incorrect blade, tooth missing	Replace blade, re-clamp part
Blade breaks	Backlash, dull blade, part moved in vise	Remove backlash, replace blade, re-clamp part
Excessive motor/gear box noise	Low oil, excessive backlash	Add oil, remove backlash
Head is jerky	Binding components, air in system	If oil is full bleed head cylinder
Motor hums or runs slow	Check power source fuses, hood interlock	Replace fuses, close hood
Motor runs backwards	Leads on incoming power are not correct	Have a qualified electrician fix
No power to the machine	Check power source fuses, hood interlock	Replace fuses, close hood
Vises do not operate or are slow	Incoming air pressure, regulator pressure	Increase air pressure, set regulator higher
Head stops down feeding	Lack of air, flow control valve adjustment	Increase air pressure, adjust valve
Head returns slow	Gib strip adjustment, air return valve is closed	Adjust gib, open air return valve
Tolerances slipping	Feeder set too fast, blade, overfeeding	Slow feeder, adjust blade thickness
Unsquaring cutting	Feeder set too fast, blade thickness	Slow feeder, adjust blade thickness
Motor runs hot	Incoming voltage too high	Power should be +/- 10%
Head crashes down	Low or no oil in head feed cylinder	Add oil to cylinder, repair any leaks
Machine will not restart	Security locked out, piece counter not cleared	Turn key to on position, clear counter
Machine will not start	E-stop is activated, out of stock	Reset E-stop, check feed vise clearance



## ELECTRICAL COMPONENTS

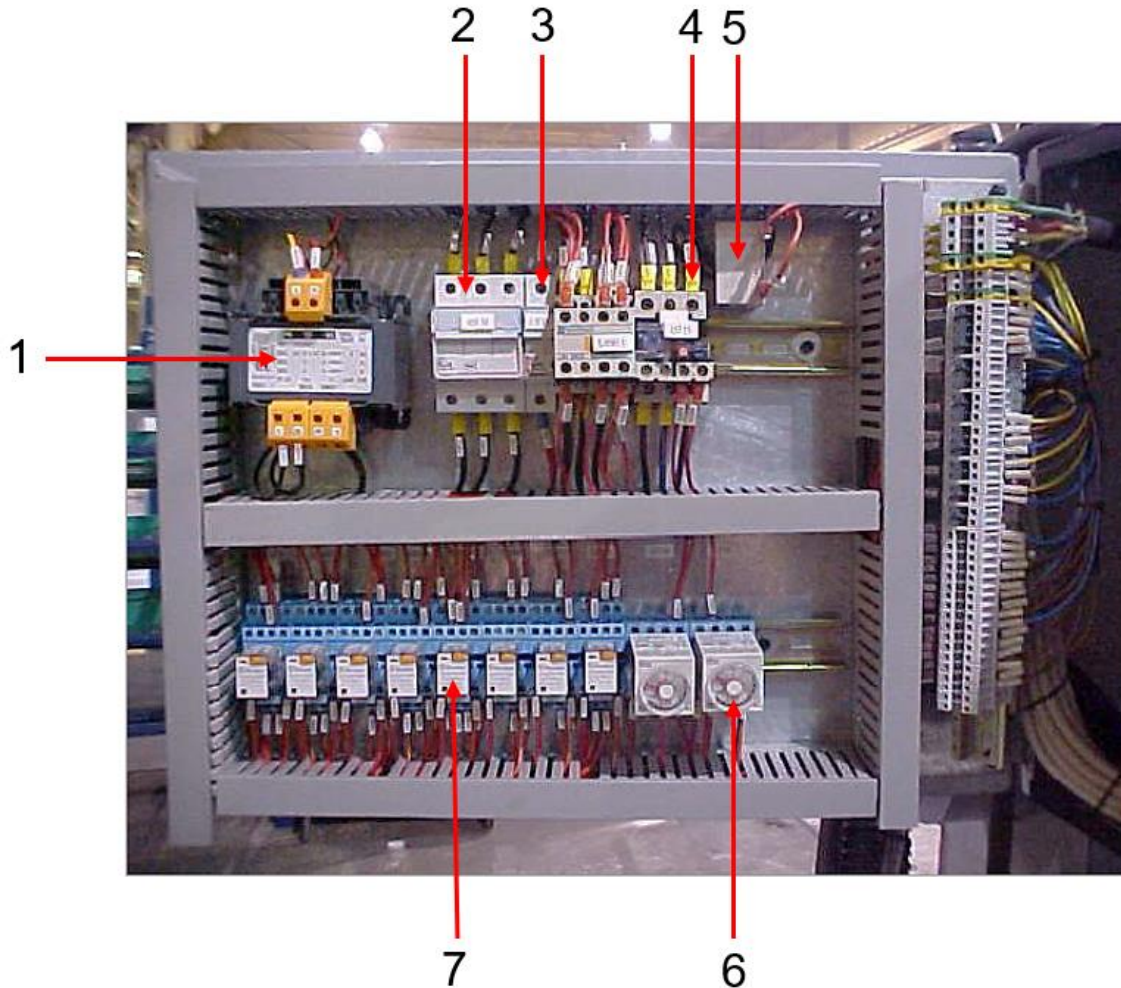

Pos. Number	Part No.	Description
1	300210	Transformer, Duel Voltage 150VA
2	77526	Fuse, 15 Amp
	77523	Fuse, 2 Amp
3	300203	Fuse Holder – Swing Out
4	300603	Overload Relay
	301824	Overload Holder
5	300213	Coil, Inductive Pick-up for blade protection units
6	300208	Dwell Timer
7	300209	Relay
	300302	Empty Electrical Box 370S

**PNEUMATIC SYSTEM SCHEMATICS**

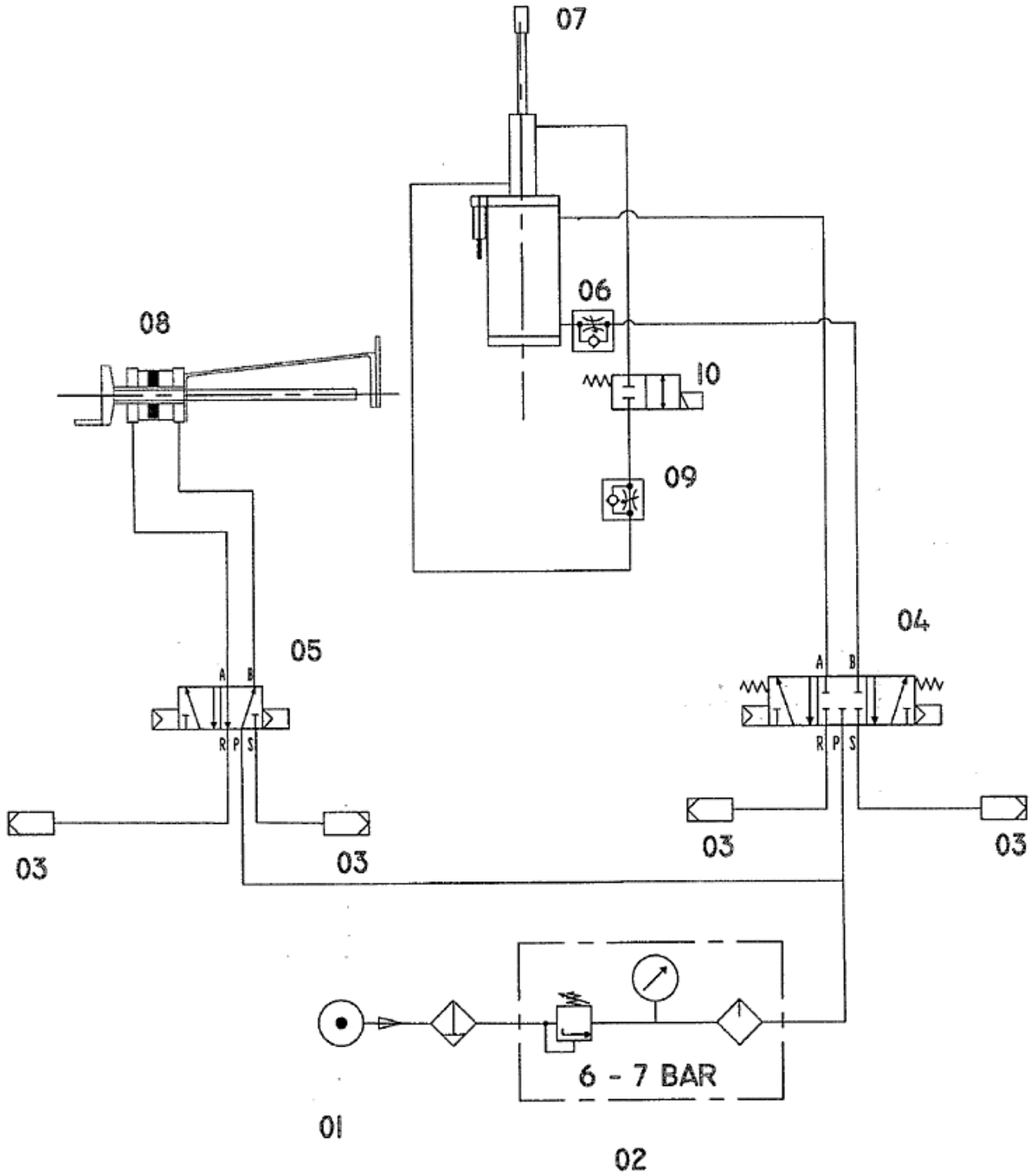

## EXPLODED VIEWS AND PART LISTS

### Head Cylinder Unit:

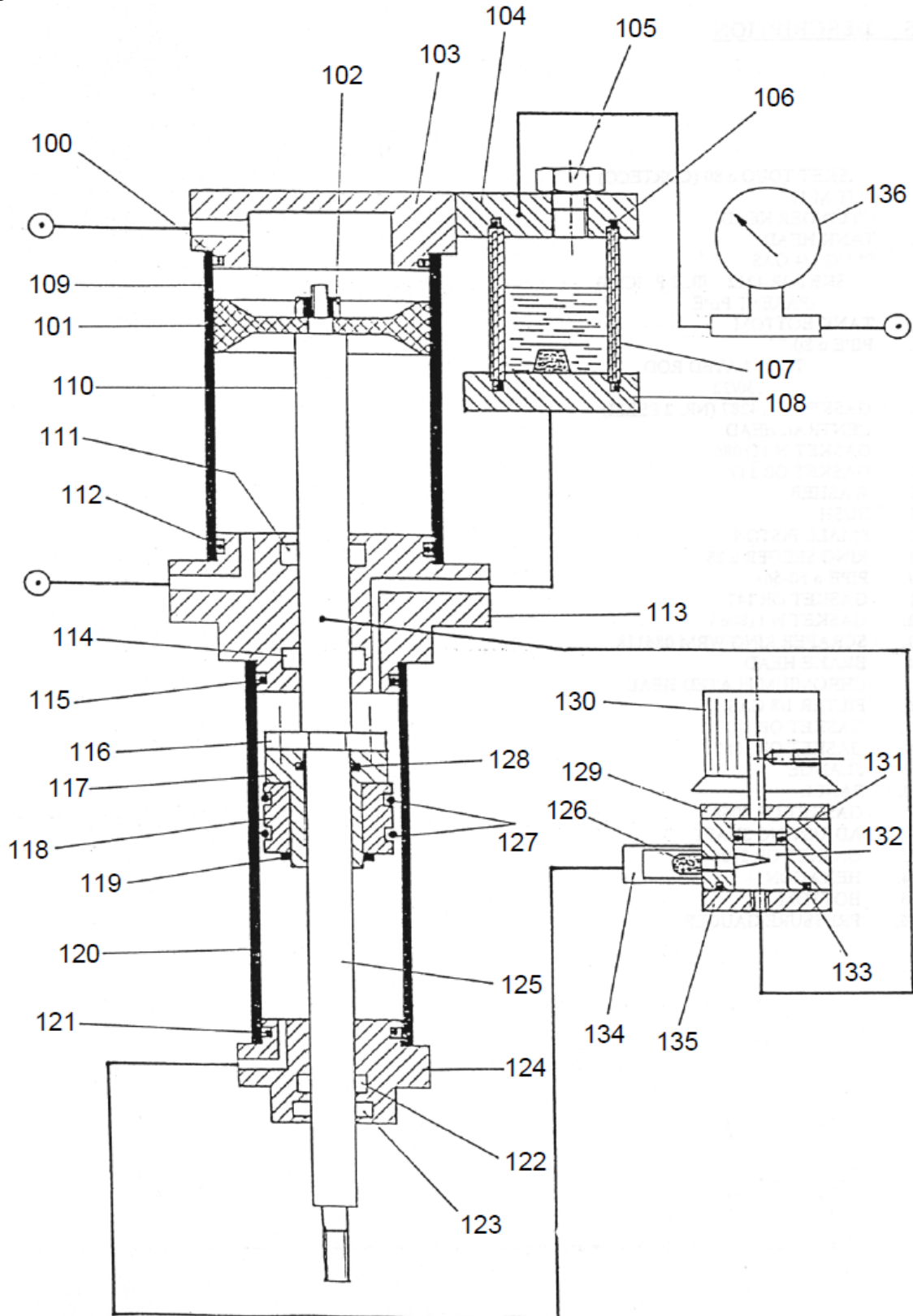

**Head Cylinder Unit:**

<u>Item</u>	<u>Part Name</u>	<u>Part No.</u>
100	Gasket	
101	Gasket	
102*	Nut	
103	Cylinder Head	
104	Tank Head	
105	Plug	
106	Gasket – 2 pieces	11558
107	Transparent Pipe	300273
108	Tank Bottom	
109	Pipe	
110	Chromium Plated Rod	
111	Gasket	
112	Gasket	
113	Central Head	
114	Gasket	
115	Gasket	
116*	Washer	302164
117*	Bushing	
118*	Small Piston	
119*	Seeger Ring	
120	Pipe	
121	Gasket	
122	Gasket	
123	Scraper Ring	
124	Brake Head	
125	Chromium Plated Head	
126	Filter	
127	Gasket	
128	Gasket	
129	Flange	
130	Panel	
131	Gasket	
132	Adjusting Shaft	
133	Gasket	
134		
135		
136	Pressure Gauges	
Complete Cylinder		301332
* Cylinder Repair Kit (Items: 101, 106, 111, 112, 114, 115, 122, 123, 126, 127, 128, 131, 133)		300155

**Bedplate Unit:**

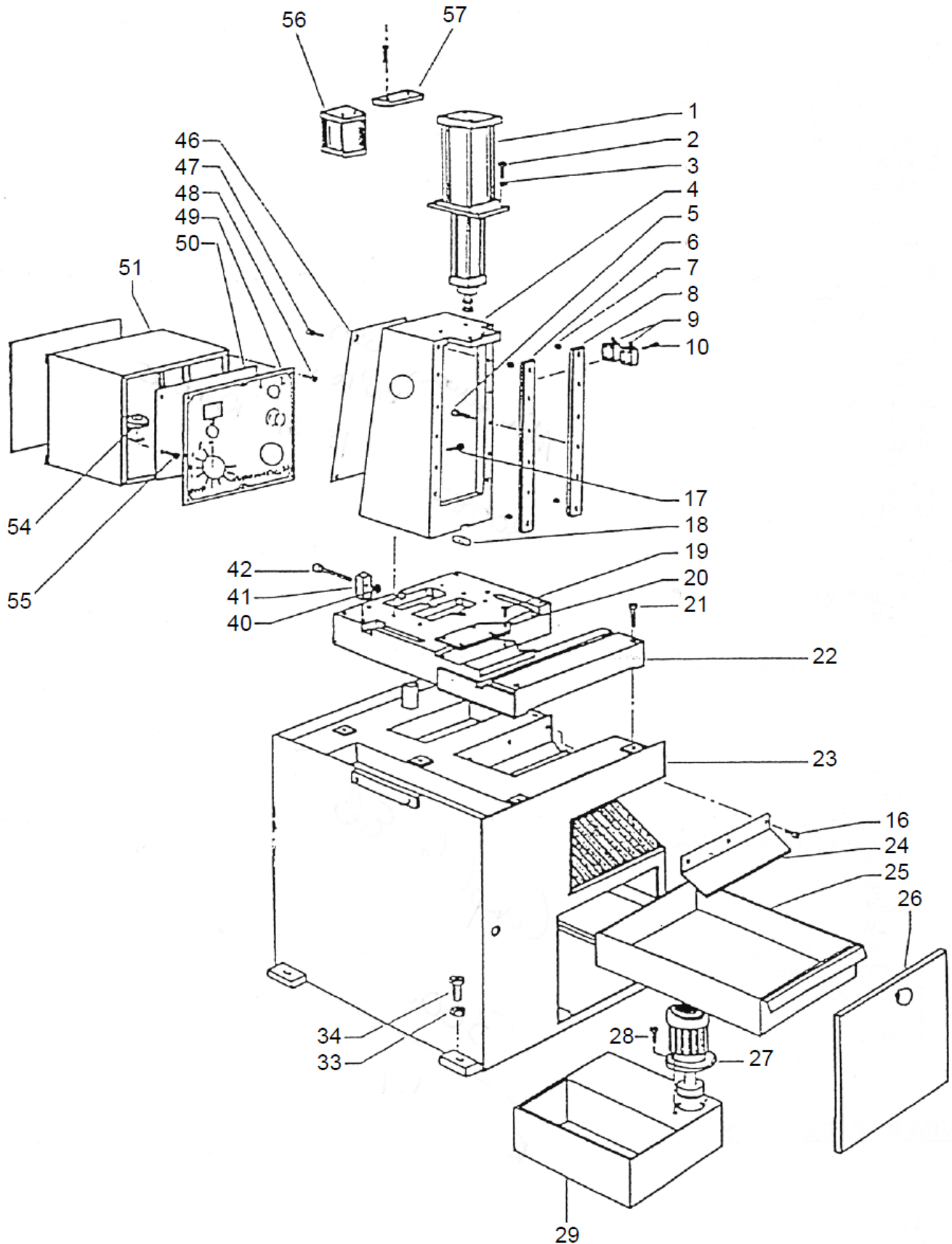

**Bed Plate Unit:**

<u>Item</u>	<u>Part Name</u>	<u>Part No.</u>
1	Head Piston	
2	Screw	
3	Washer	
4	Column	
5	Screw	
6	Left Guide	
7	Bushing	
8	Right Guide	
9	Limit Switch	300211
10	Screw	
16	Screw	
17	Screw	
18	Keyway	
19	Screw	
20	Blade	
20	Blade – Right Hand	300201
21	Socket Head Cap Screw (M12-1.75 x 110mm)	78824
22	Base	
23	Bedplate	
24	Chute	
25	Tank	
26	Cap	
27	Motor Pump	300176
28	Screw	
29	Tank	
30	Roller Chute Support (Not Shown)	
31	Nut (Not Shown)	
32	Screw (Not Shown)	
33	Nut	
34	Sleeve	
35	Screw (Not Shown)	
36	Set Screw (Not Shown)	
40	Nut	
41	Vise Adjustment Block	
42	Screw	
46	Exhaust Chute	300230
47	Screw	
48	Screw	
49	Control Panel	
50	Electric Panel	
51	Electric Case	
54	Nut	
55	Screw	
	Complete Electrical Box	300690
	Electrical Box Only	300692
	Main Power Push Button	300824
56	Reservoir	
57		

**Head Unit:**

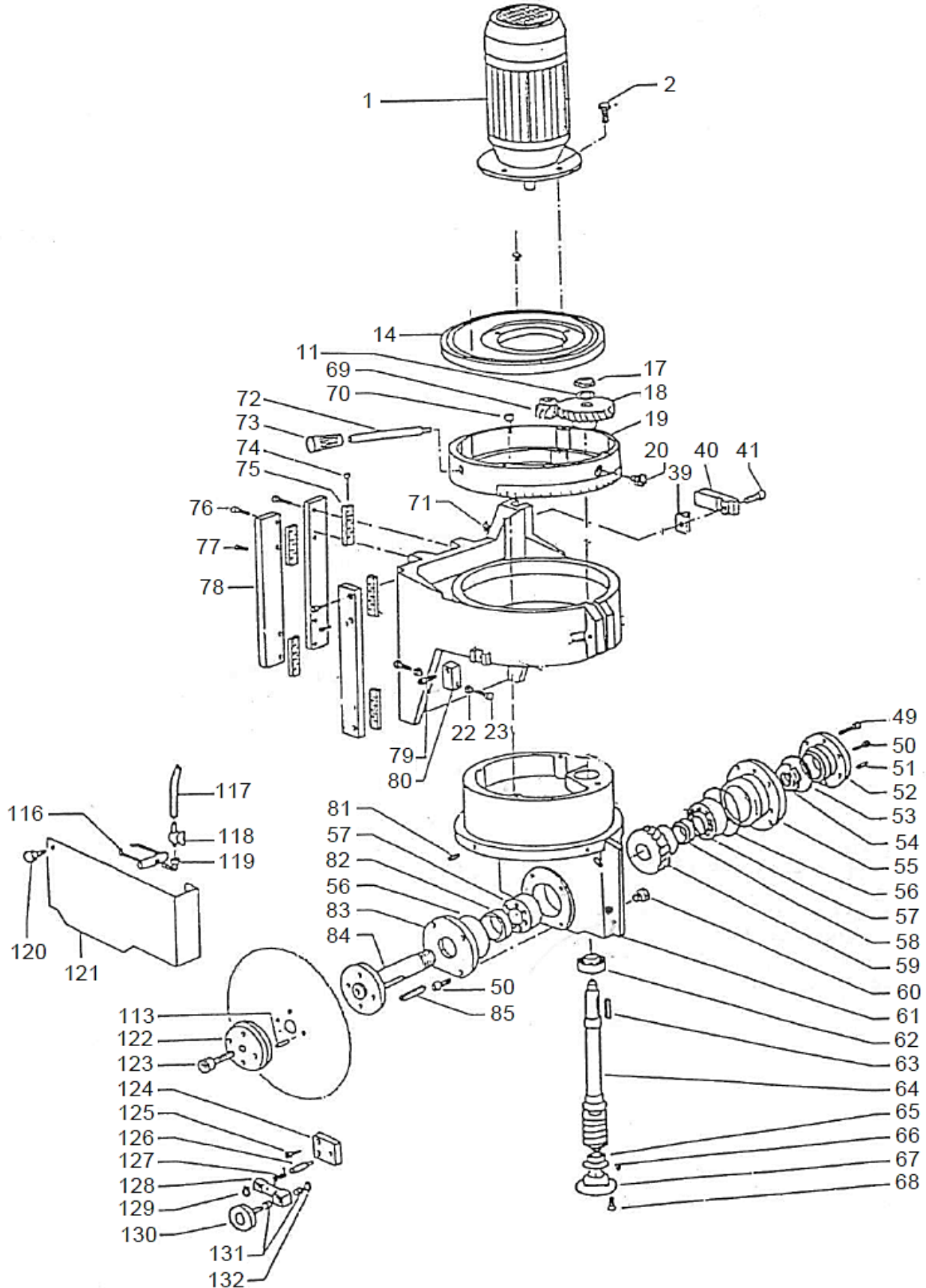

**Head Unit:**

<u>Item</u>	<u>Part Name</u>	<u>Part No.</u>
1	Motor 220V	300117
2	Screw	
7	Stopping Block (Not Shown)	
11	Washer	301336
14	Head Ring	
16	Screw (Not Shown)	
17	Nut	300239 or 300675
18	Gear (300675 old)	300230
19	Cover	
20	Oil Level Plug	
21	Head Bearing (Not Shown)	
22	Nut	
23	Screw	
38	Head Cylinder (Not Shown)	
39	T-Nut	301979
40	End Stroke Flash - Cam	300202
41	Screw, Handle (300612)	300354
42	Bearing Pivot (Not Shown)	
43	Screw (Not Shown)	
44	Pivot Bearing (Not Shown)	
46	Closing Pivot (Not Shown)	
47	Protection Carter (Not Shown)	
48	Stopping Ring (Not Shown)	
49	Socket Head Cap Screw (M12 x 12mm)	78809
50	Set Screw (8mm x 16mm)	81572
51	Set Screw	
52	Bearing Cover	
53	Sealing Bearing	5611
54	Self-Locking Nut	301335
55	Bearing Cover	
56	Sealing Ring	29637
57	Bearing	300686
58	Spacer	301338
59	Helical Wheel 25/50 RPM	300676
59	Helical Wheel 50/100 RPM	300677
60	Oil Blow-off Plug	
61	Head	
62	Bearing	300678
63	Keyway	301334
64	Worm Screw 25/50 RPM	300680
64	Worm Screw 50/100 RPM	300677

<u>Item</u>	<u>Part Name</u>	<u>Part No.</u>
65	Bearing	300678
66	Sealing Ring	300682
67	Bearing Cover	301333
68	Screw	
69	Motor Gear (300683 old)	300238
70	Screw (M5 x 8mmL)	78899
71	Oiler	
72	Head Rotation Lever	
73	Lever Handle	
74	Screw (M6-1.0 x 80mm)	300159
75	Gib	300197
76	Screw (M10-1.0 x 80mm)	300161
77	Screw (M4-.07 x 25mm)	300162
78	Gib Flat	300163
79	Screw	
80	Clamping Block	
81	Elastic Plug	
82	Bearing (Seal is 300434)	300684
83	Cover	
84	Blade Shaft	300435
85	Keyway	301366
113	Cylindrical Plug	300436
116	Spout Breaking	300411
117	Rubber Pipe	
118 & 119	Coolant Valve & Fitting	300410
120	Handwheel	
121	Disk Repair	
122	Blade Flange	300437
123	Socket Head Cap Screw (M16-2.0 x 40mm)	300438
124*	Brush Bearing	
125*	Screw	
126*	Bearing Pivot	
127*	Spring	
128*	Brush Level	300164
129*	Stopping Ring	
130*	Brush	300165
131*	Bushing	300164
132*	Stopping Ring	300164
* Complete Brush Assembly (124, 125, 126, 127, 128, 129, 130, 131, 132)		300626
Complete Air Regulator Feeder		300694
Air Regulator Only		300356
Complete Head Assembly		300128



**Vise Unit:**

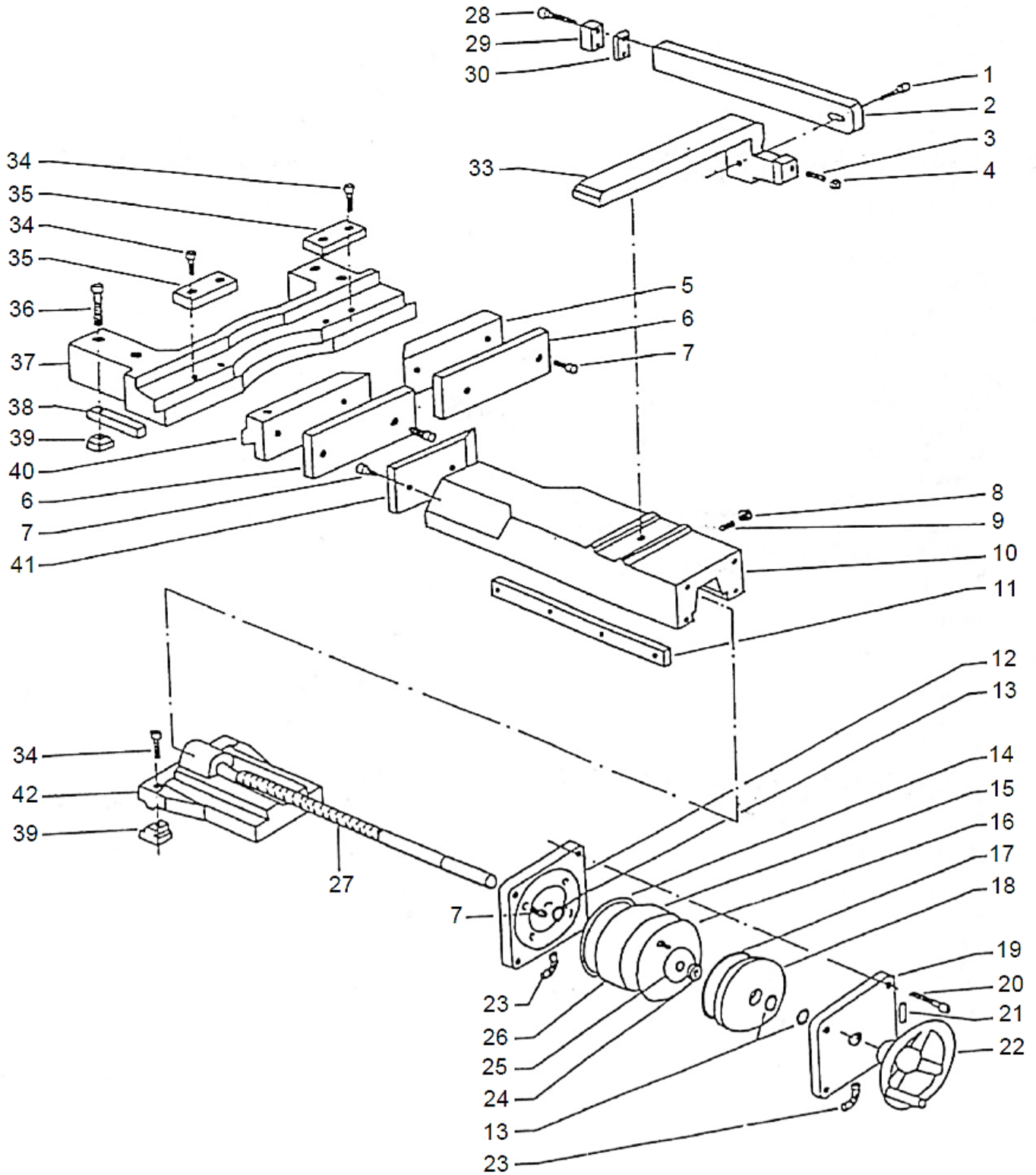

**Vise Unit:**

<u>Item</u>	<u>Part Name</u>	<u>Part No.</u>
1	Screw	
2	Rod	304036
3	Set Screw	
4	Nut	
5	Right Jaw Holder	300194
6	Jaw	300876
7*	Socket Cap Screw (M8-1.25 x 20mm)	80521
8	Set Screw	
10	Vise Slider	
11	Gib	
12*	Slider Side Cap	
13*	Sealing Ring	
15*	Gasket	
16*	Cylinder Liner	
17*	Sealing Ring	
18*	Cylinder	300191
19*	Front Cap	
20*	Screw (M10 x 70mm)	
21	Elastic Pin	
22	Handwheel with Knob	300142
23	Pipe Fitting	
24*	Spacer	
25*	Spacer Holder Flange	
26*	Screw	
27	Vise Screw	300353
28	Screw	
29	Block	300167
30	Small Rubber	300166
31	Screw (Not Shown)	
32	Washer (Not Shown)	
33	Support	304037
34	Screw	301980
35	Jaw Holder Clamping Plate	301986
36	Screw	301981
37	Vise Support	300193
38	Vise Support Feather	301984
39	Small Block	301979
40	Left Jaw Holder	300194
41	Jaw	300875
42	Vise Slide Support	300352
Main Clamping Vise		300196
* Air Vise Repair Kit		300914
Seal Kit for Main Vise		301325

**Non-Ferrous Head Unit:**

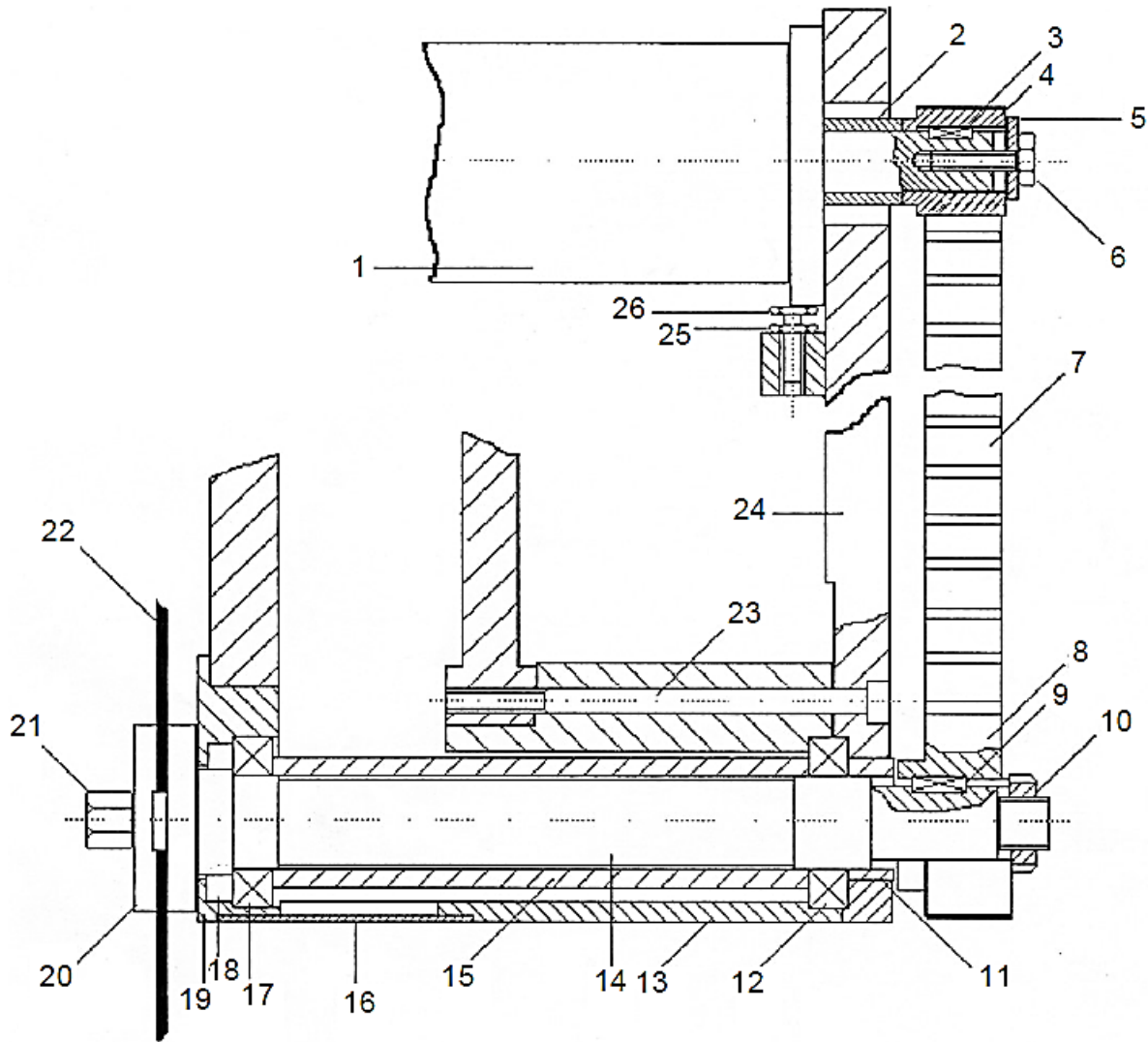

<u>Item</u>	<u>Part Name</u>	<u>Part No.</u>
1	Motor – 220V	300117
2	Spacer	
3	Key	
4	Upper Cog Pulley	79931
5	Washer	
6	Bolt	
7	Drive Belt	300355
7	Drive Belt (510mm)	301976
8	Cog Pulley (Lower)	300700
	Cog Pulley (Lower)	300594
9	Key	300705
10	Spindle Nut	300704
11	Spacer	301313
12	Bearing	300424
13	Pipe	

<u>Item</u>	<u>Part Name</u>	<u>Part No.</u>
14	Blade Shaft	300423
15	Spacer	
16	Cover Plate	
17	Bearing	300426
18	Gasket	300706
19	Flange	301312
20	Blade Flange	301312
21	Spindle Bolt	300425
22	Blade	
23	Bolt	
24	Support Plate	
25	Lock Nut	
26	Bolt	
Complete Head Assembly 440 Volt		300232

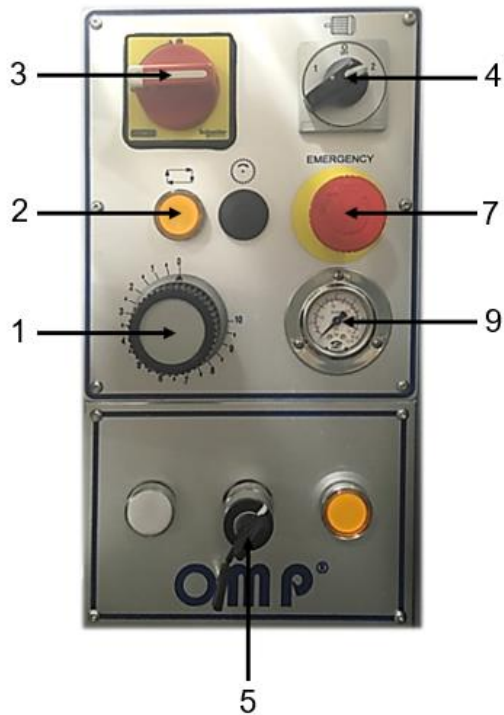

<u>Item</u>	<u>Part Name</u>	<u>Part No.</u>
1	Flow Control Head	300215
2	Cycle Start Button	300219
3	Main Power Switch	300206
4	Blade Speed Switch	300233
5	Lock Out Switch with Key	300204
7	Emergency Stop	300351
9	System Pressure Gauge	300214

**Items not shown:**

<u>Part Name</u>	<u>Part No.</u>
Hood Limit Switch	300212
Air Feed Regulator	300356
4-Way Valve	79914
Cylinder Head Lift (Old Style, for Steel Frame Hoods)	300199
Cylinder Head Lift (New Style, requires Eyelets 300446)	300445
Gas Shock Assembly	716697
Gas Lift Shock	300445
Eyelets Fittings of Gas Lift	300446
6 HP Motor	300851

<u>Part Name</u>	<u>Part No.</u>
Valve for Regulating Feed Vise	300195
Table Cover Plate	300198
Hex Wrench	300220
Bar Stop	300228
Oil Reservoir	300273
Plexi Glass Hood	300277
Air Regulator Head Assembly	300813
Hood Hinge	301819
Shock Mount Plastic	301820
Coil	88130045

***Please contact factory for current prices.***

## ORDERING INFORMATION

Parts are available for direct purchase from Dake or through a distributor. When placing a parts order, you will need to provide the part number, name of part, and model number. All parts shipped F.O.B. Factory in Grand Haven, MI.

## **DEACTIVATING THE MACHINE**

If the machine is not going to be in use for a long period of time it is recommended that you do the following:

1. Unplug machine.
2. Empty coolant tank.
3. Carefully clean and grease machine.
4. If necessary cover the machine.

## **DISMANTLING THE MACHINE**

If this machine is permanently demolished and/or scrapped, divide the material to be disposed of and dispose of them in accordance to local disposal laws. This includes raw materials such as metals, electrical components, and special waste such as old oils.