

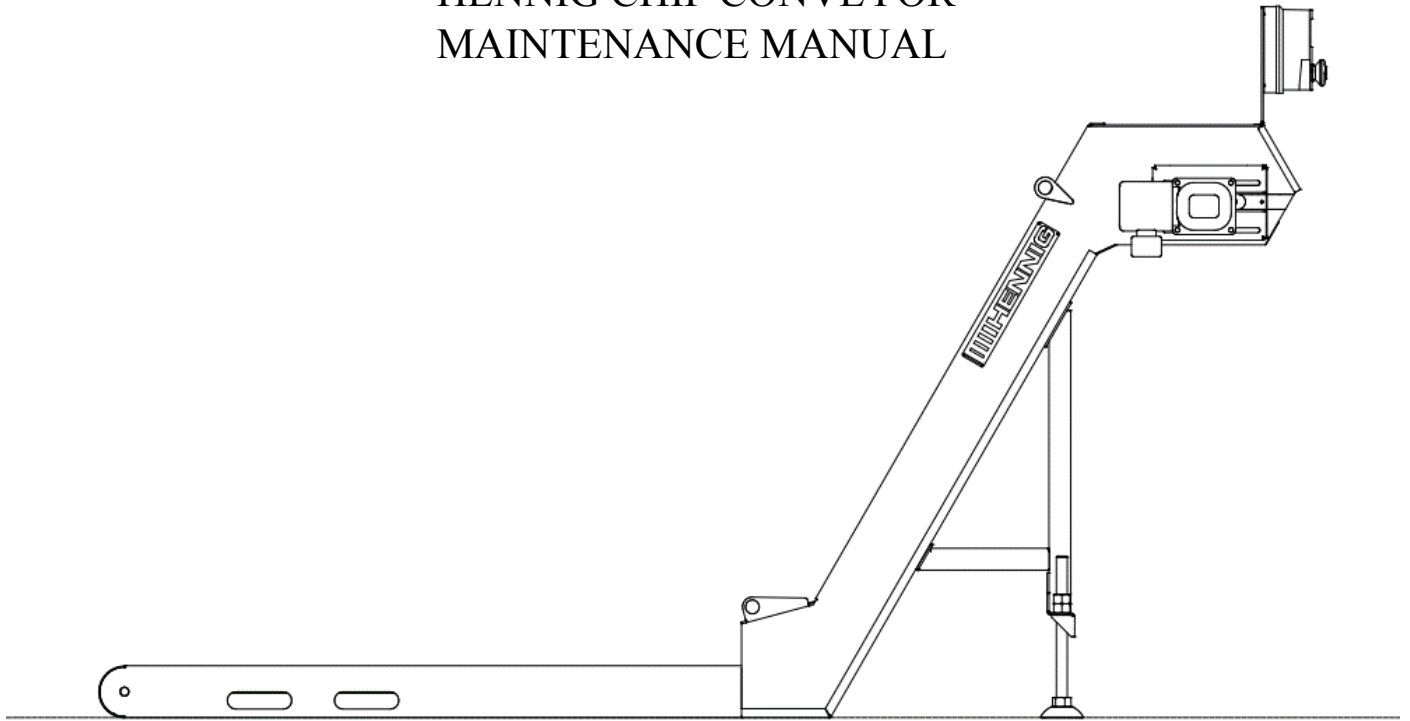

HENNIG CHIP CONVEYOR
MAINTENANCE MANUAL



HENNIG, INC.
9900 N. ALPINE ROAD
MACHESNEY PARK, IL 61115
(815)-636-9900 (PH.)
(815)-636-1988 (FAX)
WWW.HENNIG-INC.COM

MANUAL REVISION DATE: 03/23/2016

HENNIG CHIP CONVEYOR

The Hennig Chip Conveyor is available in a variety of configurations to be adaptable to a wide array of machine tool applications. The Hennig Chip Conveyor is designed to remove chips and debris from coolant used in machine tool applications. The life of the Hennig Chip Conveyor can be extended greatly by following the instructions and guidelines in this manual. For assistance in new applications or questions regarding your system, please contact a Customer Service Representative at our U.S. manufacturing facility:

Hennig, Inc.
9900 N. Alpine Road
Machesney Park, IL 61115
(815) 636-9900
(815) 636-1988 (Fax)

Index

Introduction to Hennig Chip Conveyors.....	Page 2
Ordering Instructions for Parts	Page 2
Installation and Start-up Instructions	Page 3
Scheduled Maintenance Procedures	Page 4
Belt Removal, Maintenance, & Installation Procedure	Page 5 & 6
Parts List and Drawings	Page 7 - 10

IMPORTANT INSTRUCTIONS FOR ORDERING PARTS

It is important to have the following information available when ordering parts:

- Hennig Chip Conveyor Model Number*
- Hennig Serial Number*
- Part Name
- Manual Revision Date

(*) - May be found on the name plate located on the side of the head section of the conveyor.

INSTALLATION AND START-UP INSTRUCTIONS

Your new Hennig Chip Conveyor has been tested and inspected prior to delivery to ensure it functions properly upon installation. Please follow the following instructions for effective startup of your system:

1. Visually inspect your system for any shipping damage. Contact Hennig, Inc. immediately if damage has occurred.
2. Roll entire system (conveyor and tank) into position so that the conveyor chip chute is located under the machine coolant/chip discharge.
3. Level coolant tank using leveling screws mounted on the sides. After the tank is level, adjust the support feet (or casters) of the filter/conveyor for sufficient support. Tighten locknuts when leveling screws and support feet (or casters) are correctly adjusted.
4. Install wiring to electrical box or switch. Be sure to use the correct voltage and phase for the system. Proper rotation of the conveyor belt may be obtained by reversing power connection.
5. Make sure all foreign objects such as shipping papers, crating, cleaning rags, etc. are removed from the conveyor prior to start-up.
6. Check the belt tension of the conveyor. Adjust tension using tension bolts and lock in place using jam nuts if required.
7. Fill the coolant tank to the level indicated on the Chip Conveyor System layout drawing. Typically the coolant level can be maintained approximately 2" below the covers of the tank. Check for any leakage and contact Hennig, Inc. if any occurs.
8. Install all required plumbing to pumps, chillers, etc. Ensure that all fittings are correctly tightened before starting pumps.
9. Install wiring for pumps, chillers, oil skimmers, hi/low float switches, etc. to machine electrical system if required. Ensure that all electrical service meets local codes.
10. Make sure hands, feet, and clothing are clear of all moving parts before start-up.
11. Make sure all drive train guarding is securely attached before start-up.
12. Locate a chip hopper under the conveyor discharge for collection of chips.
13. Start-up machine and Hennig Chip Conveyor System.

Note: The conveyor should be set up to run continuously while machine tool is discharging coolant and chips. Unusually high amounts of chips during a short period of time can result in jamming the conveyor.

CAUTION:
KEEP HANDS, FEET, AND CLOTHING CLEAR
OF MOVING PARTS OF CONVEYOR

SCHEDULED MAINTENANCE PROCEDURES

Daily Maintenance:

1. Check coolant level in tank. Fill if necessary. Never fill tank with pumps in operation – overflow may occur due to overfilling once pumps are shut off.
2. Insert 1-3 shop rags in the discharge of the conveyor to run through the bottom in an effort to clean out any chips. Repeat if necessary. Caution: Do not stick hands into harm's way of conveyor belt – avoid pinch points.

Every 1,000 Hours of Use Maintenance:

1. Check tension of conveyor “hinge/scrapper belt” by checking the torque setting of the “adjusting screws” for the “take-up bearings” on each side of the head. Torque to be set at 25 in-lbs. (*Figure #3*)
2. The “current sensor” is set at the factory. Adjustment of current sensor may compromise motor protection.
3. Grease “take-up bearings” with grease gun. Do not over grease – seals can be damaged. (*Figure #2&3*)
4. Inspect “hinge/scrapper belt” for wear or damage. (*See Hinge/Scrapper Belt Removal and Installation Procedure if necessary*)
5. Maintain pumps, chillers, oil skimmers, etc. per manufacturer's instructions.

CAUTION:
ALWAYS DISCONNECT POWER BEFORE
PERFORMING ANY MAINTENANCE

BELT REMOVAL, MAINTENANCE, AND INSTALLATION

Hennig Chip Conveyors are typically equipped with either a “hinge belt” or “scraper belt” dependent upon the specific application. The “scraper belt” is wide open for viewing of critical components so maintenance requirements are easily seen. On the other hand, inspection of the

“hinge belt” can be somewhat more difficult. General inspection of either belt type can be accomplished at the discharge opening at the head of the conveyor, by removal of the slide lid, or through openings in the trough. Detailed inspection of a “hinge belt,” however, requires complete removal of the belt from the conveyor body to provide complete access to all the integrated components.

Hinge Belt Assembly Removal:

1. Disconnect power source to conveyor.
2. Drain tank or remove conveyor from tank as required.
3. Run conveyor until the “master shaft” (identified as shaft with cotter pins and washers) are positioned at the slot opening located near the discharge of the conveyor (so that the “master shaft” may be knocked out). *Note: if the conveyor is jammed and cannot be run, go to step #4. (Figure #3)*
4. Remove “flip lid,” “bearing cover” and “slot guards” (*found at discharge end of conveyor*).
5. Remove motor mounting screws and nuts and pull motor off drive shaft. (*Figure #6*)
6. Turn “take-up bearing adjusting screws” counter-clockwise to reduce tension of “hinge belt.” Be sure to note the position of the bearings prior to reducing tension so the correct tension may be easily set upon re-installation. (*Figure #3*)
7. Remove “cotter pin” and “washer” from “master shaft.” Slide the “master shaft” out of the belt assembly. If the “master shaft” cannot be moved into removal position (*as stated in step #3*), any “shaft” located in the slot near the discharge of the filter/conveyor may be removed by, first, grinding the crimp from the end of the “shaft” to allow for removal. (*Figure #4*)
8. At this point, the belt should easily be disconnected. Re-install the “master shaft” into the belt in the top section only to ensure easy belt removal.
9. Remove the belt assembly from the conveyor by pulling out the bottom end of the belt assembly first (*the “master shaft” should trail the belt assembly as it comes out*). (*Figure #5*)

CAUTION:
ALWAYS WEAR PROTECTIVE GLOVES
WHEN HANDLING A HINGE BELT

Hinge Belt Assembly Maintenance:

1. Clean belt – remove excessive buildup of chips and swarf.
2. Visually inspect belt for damage and wear.
 - a. Ensure that rollers are rotating freely and check for wear. (*Figure #4*)
 - b. Check belt shafts for wear. (*Figure #4*)
 - c. Ensure that scrapers are still effective – replace if necessary.

- d. Check “hinge plates” for damage. *(Figure #4)*
3. Check guide rails, sprockets, and conveyor body for wear or damage.

Hinge Belt Assembly Installation:

1. With “master shaft” installed as stated in the “Hinge Belt Assembly Removal” procedure (*step #8*), feed the belt in (master shaft first) on lower rail system until the ends of the belt meet back up at the discharge of the filter/conveyor. *(Figure #5)*
2. Remove the “master shaft” and mesh the two ends of the belt assembly together. Slide the master shaft through the mating parts of the belt assembly (*install “washers” and “cotter pin” on each end*). *(Figure #3 & #4)*
3. Adjust the belt tension by checking the torque setting of the “adjusting screws” for the “takeup bearings” on each side of the head. Torque to be set at 25 in-lbs or adjust “take-up bearings” to original position. *(Figure #3)*
4. Install gearmotor by sliding over shaft and key, and replace motor mounting screws and nuts. *(Figure #2&6)*
5. Replace all guards and covers.
6. Re-install conveyor into tank and add coolant as required.
7. Connect power source.

Video of belt assembly removal can be found at:

<http://www.hennig-inc.com/products/chip-conveyors/conveyor-belt-assembly-video/>

**SPARE HINGE/SCRAPER BELT KITS
AND COMPLETE BELT ASSEMBLIES
CAN BE PURCHASED AT
HENNIG, INC.**

PARTS LIST AND DRAWINGS

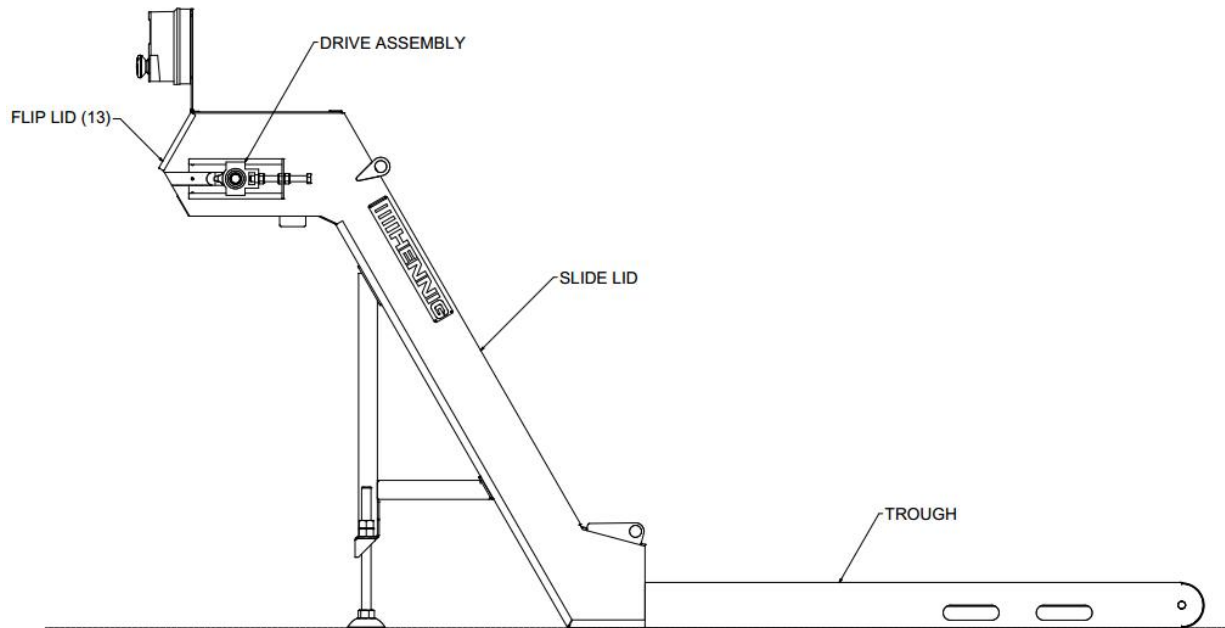

FIGURE #1

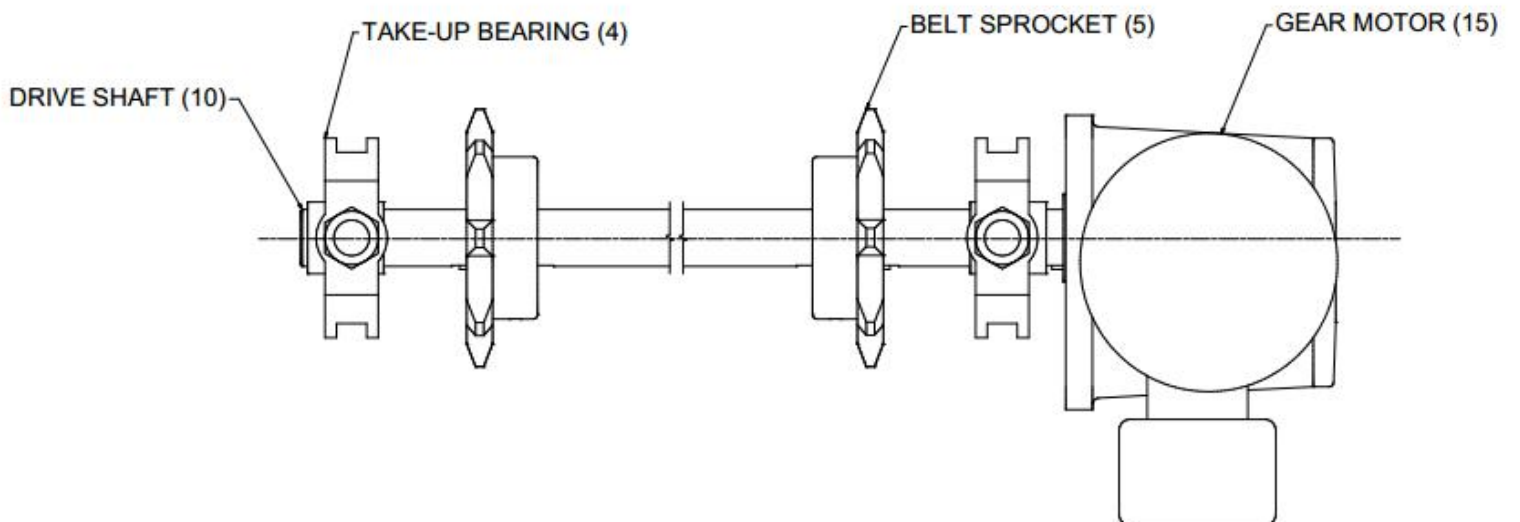

FIGURE #2

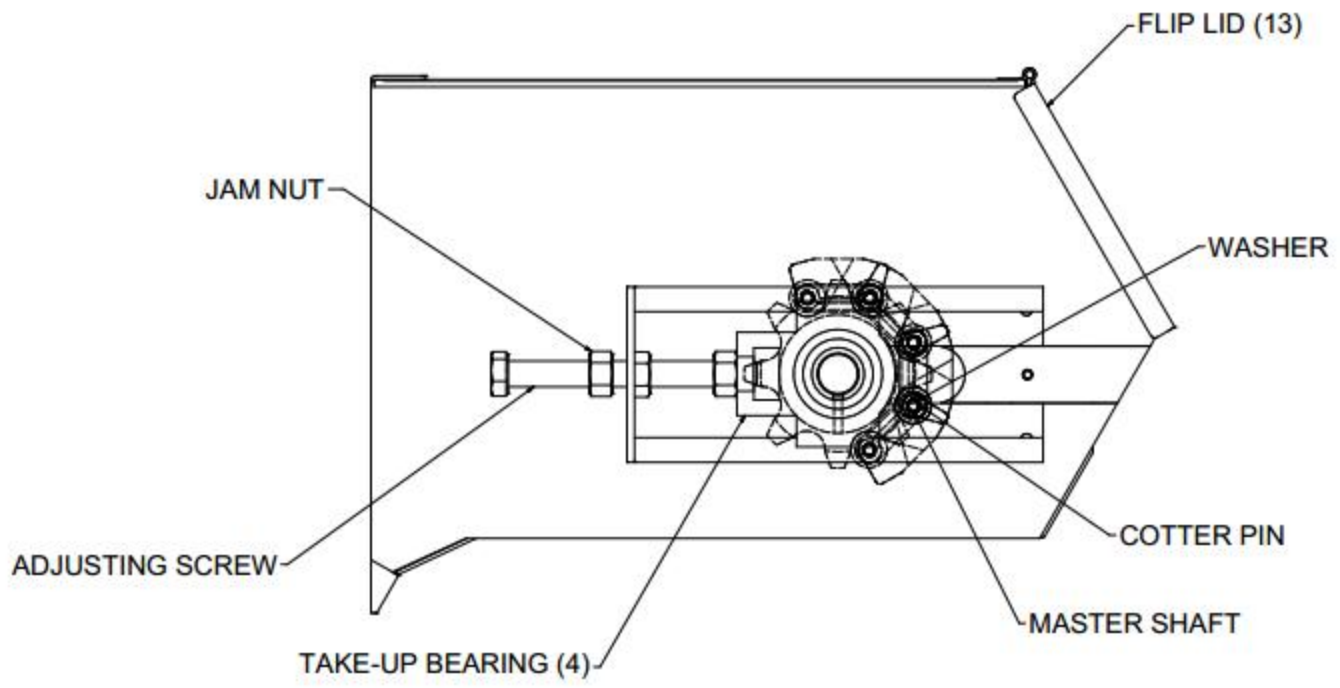

FIGURE #3

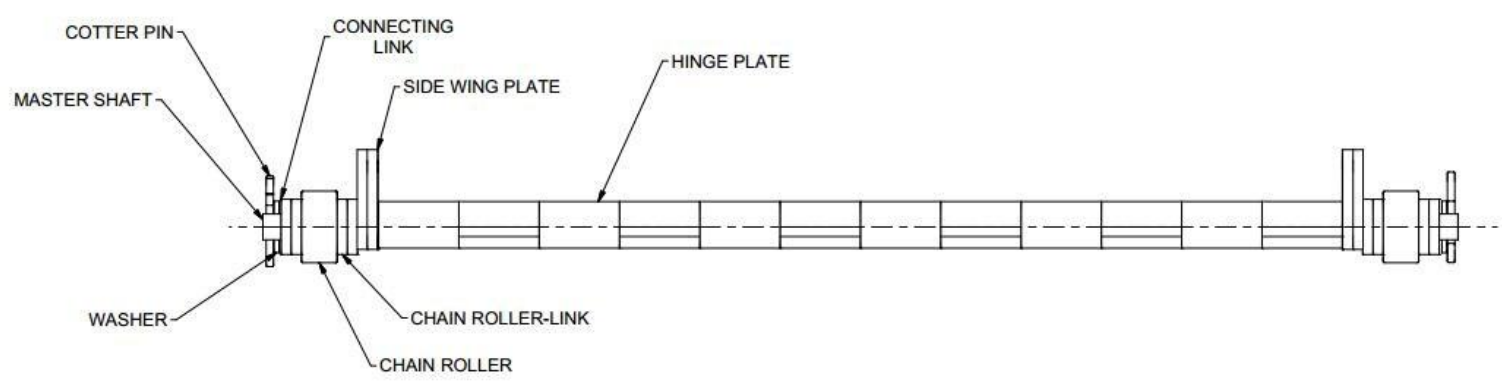

FIGURE #4

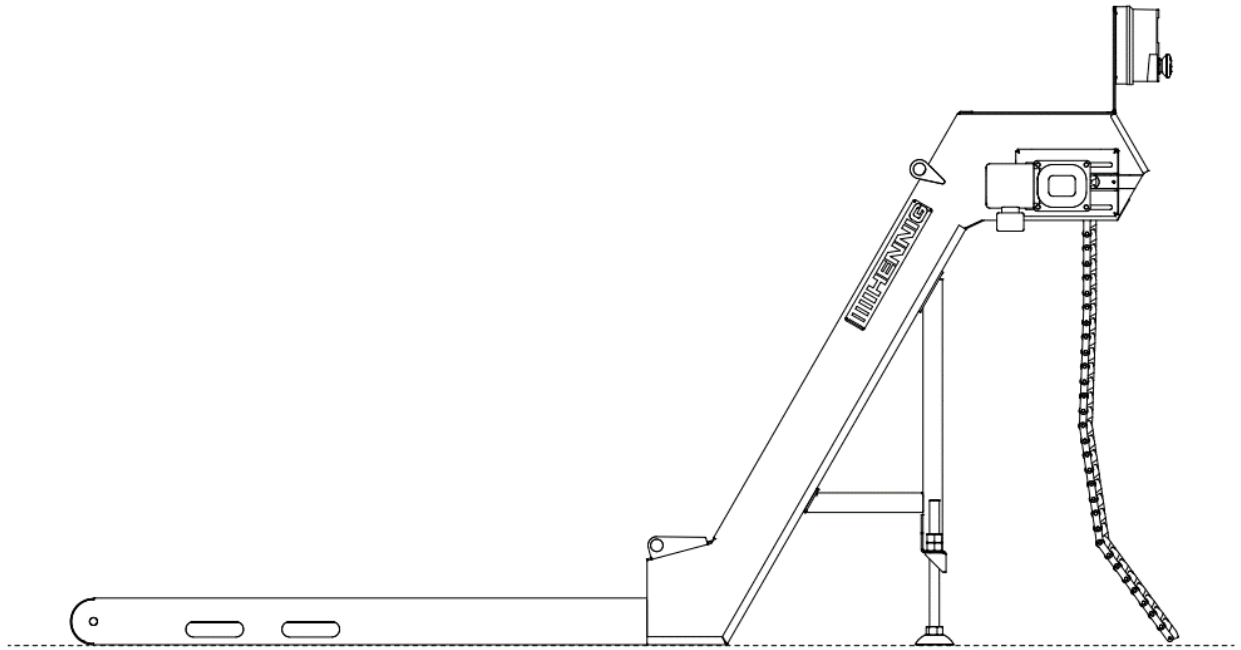

FIGURE #5

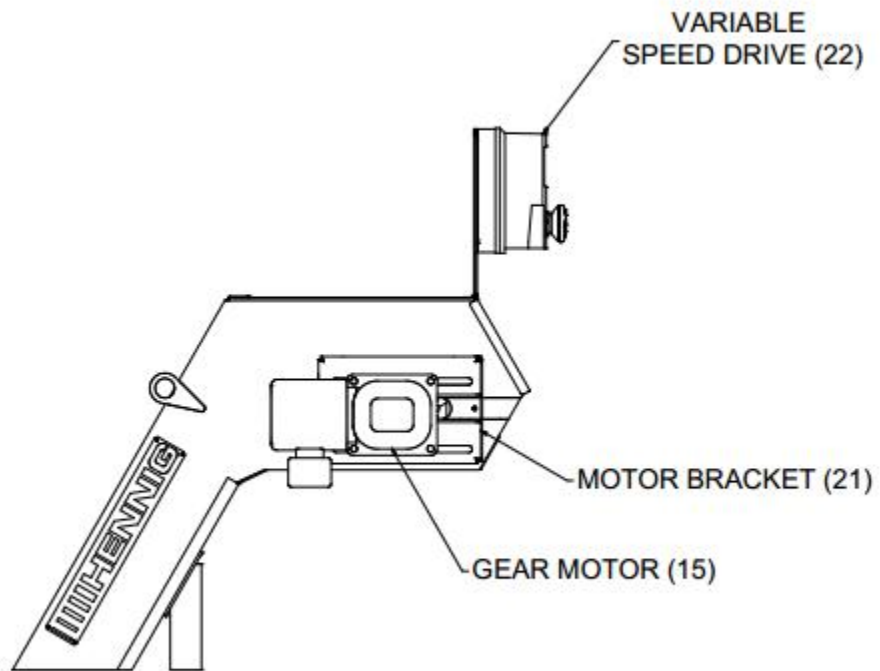
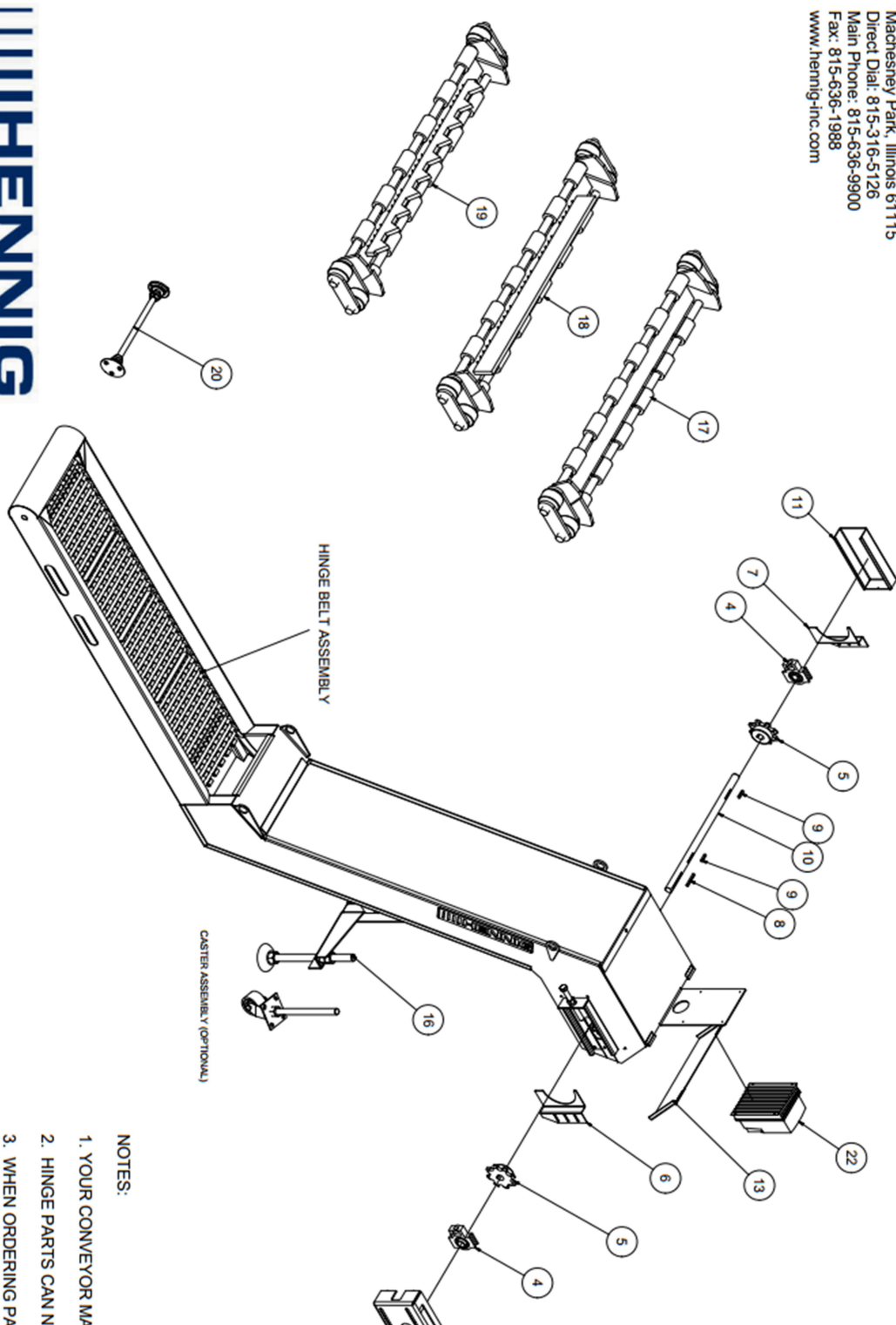

FIGURE #6

To request a quote please contact us at:
 Hennig Inc.
 9900 North Alpine Road
 Machesney Park, Illinois 61115
 Direct Dial: 815-316-5126
 Main Phone: 815-636-9900
 Fax: 815-636-1988
 www.hennig-inc.com

DIRECT DRIVE DRIVE CHIP CONVEYOR PARTS LIST



ITEM	Part List	PART NUMBER
4	TAKE-UP BEARING	
5	BELT SPROCKET	
6	LH INNER GUARD	
7	RH INNER GUARD	
8	TORQUE LIMITER KEY	
9	BELT SPROCKET KEY	
10	DRIVE SHAFT	
11	BEARING COVER	
13	FLIP LID	
15	GEAR MOTOR	
16	ADJUSTABLE SUPPORTS	
17	STANDARD HINGE KIT	
18	HINGE KIT WITH PLAIN CLEAT	
19	HINGE KIT WITH SERRATED CLEAT	
20	IDLER SHAFT ASSEMBLY (IF PROVIDED ORIGINALLY)	
21	MOTOR BRACKET	
22	CONTROL BOX (VFD)	

- NOTES:
1. YOUR CONVEYOR MAY NOT APPEAR EXACTLY AS SHOWN.
 2. HINGE PARTS CAN NOT BE ORDERED SEPERATELY.
 3. WHEN ORDERING PARTS, PLEASE HAVE MODEL & SERIAL NO. INFORMATION AVAILABLE.

IIIIHENNIG
 perfect machine protection.