



www.DoALLsaws.com | 1-800-321-9913

400-S StructurALL Proposal®



Valid for 30 days from date quoted

Date:

8/8/2023

Prepared By

Distributor Contact: Dan Stumpe

Distributor Company: DoAll Sawing Products

Address:

City:

State/Prov:

Zip/Postal Code:

Country:

Reference #:

Telephone: 847-302-5249

Fax:

Email: Dstumpe@doallsaws.com

Prepared For

Customer Contact: PJ

Customer Company: Smith Machinery

Address:

City:

State/Prov:

Zip/Postal Code:

Country:

Reference #:

Telephone: 641-751-2141

Fax:

Email: PJ@smithmachinery.com

Shipping

Enter Freight Cost Below

Shipping Terms: FOB Savage, MN | Freight Quote | Lead Time:

\$

Additional Comments:

SHIP VIA METHOD

Please select one option: [X]

1. SHIP TRUCK PREPAY & ADD TO INVOICE

2. TRUCK COLLECT-CUSTOMER PREFERRED CARRIER. MUST PROVIDE TRUCK DETAILS PRIOR TO PROJECTED SHIP DATE.

Technical Specifications

Capacity	90°	45°	60°	45°	60°	w/ clamps at 0°
(in)	10.75"	10.75"	N/A	N/A	N/A	N/A
(in)	10.75"	10.75"	N/A	N/A	N/A	N/A
^a x ^b (in)	16" x 10"	10.75" x 9"	N/A	N/A	N/A	N/A

Saw Blade:

Width x Length 1" x 158"

Band Drive:

Motor HP 2 Hp VFD
 Band Speed 50-400 fpm
 Band Tension Manual

Hydraulic System:

Motor Hp N/A
 Reservoir Size N/A

Coolant System: Flood **Yes** / Mist Lubricator **OPT**

Motor Hp 1/15 Hp
 Reservoir Size 6 Gallon

Indexer:

Length per Stroke N/A
 Maximum Index Strokes Length N/A
 Remnant Length N/A

Floor Space Dimensions:

W x L X H 87" x 42" x 55"
 Material Pass Height 29"
 Machine Weight 1,200 lbs.

Electrical

Voltage Requirement 208V,230V or 460V-60Hz-3ph, Wye configuration **(Must Specify at Order Placement)**

Total Amp Draw (FLA) 7.2(208) 6.9(230) 3.5(460)Amps

Standard Equipment

- Swivel head to 45 degrees.
- Fine adjustment head feed control.
- Fixed control console.
- Rapid head down approach.
- Spring loaded, zero clearance, coolant through, carbide faced saw guide inserts.
- Quick action rack and pawl vise system w/Acme Thread.
- Gear driven band cleaning brushes.
- Variable Frequency Drive
- Heavy duty counter balance spring.
- Flange backing band wheels.

- Manual band tension.
- Recirculating coolant system.
- Discharge Tray.
- Replaceable steel wear plates on bed.
- Saw blade guards.
- Band door interlocks.
- Operation and parts manuals on USB stick.
- Recommended band speed chart.
- One (1) complimentary DoALL Bi Metal saw blade.
- Complimentary DoALL Cutting Fluids package.

DoALL Sawing Products will provide videos for setup and training to make sure your new purchase is running to its maximum productivity.

Fixed Control Console

Ergonomically placed control console for ease of operation and safety of the operator.

Variable Frequency Band Drive

The Variable Frequency Band Drive allows the operator to dial in their band speed to fine tune cutting performance supplying maximum torque to the tooth tips of the saw band.

Rapid head down w/ Feed Control

Three position head control allows the operator in rapid mode to quickly position the saw head above the material, the head will stop at position in the hold mode, and create feed rates with the micrometer adjustment in the feed mode for maximizing cutting performance.

Coolant Thru Carbide Faced Saw Guide Inserts

Supplies coolant to the blade evenly before the cut creating straighter cuts and allowing longer blade life due to coolant being supplied at the tooth tip.

Band Wheels

Flange cast steel wheels insure band tracking to prevent tooth set loss.

Rack and Pawl Vice

Time honored rack and pawl vice system using an acme thread screw minimizes setup / clamping time aiding in increased production and decreased vise maintenance.

Manual Blade Tension

Positive stop to prevent possible error of over/under tightening the band for maximum cutting rates and band life.

Band Brush

Gear driven band brush removes the chips from the blade gullets which would prevent the blade from attaining maximum cutting rates and blade life.

Counter Balance Spring

Counterbalance spring maintains constant head weight thru out the cut keeping the blade tooth load equal aiding in maximum blade life.

Warranty

One year parts only subject to the terms and conditions listed on the last page.

Optional ten year warranty is available. See Details Below.

Sawing Machine Price (includes standard electrics)

Model 400-S	Order No.	Price Each	Qty	Sub Total
		400-S	\$16,995.00	1

Machine Accessories	Order No.	Price Each	Qty	Sub Total
A. Full Cycle attachment provides pneumatic head raise/visc operations allowing for head raise to a pre-determined height after the cut in auto mode. Pneumatic operations remain active in manual mode.	1008819	\$3,000.00	0	\$0.00
B. 5 ft Medium-duty idler conveyor 16" between frames. Roller capacity 850 lbs.	231546	\$1,520.00	0	\$0.00
C. 10 ft Medium-duty idler conveyor 16" between frames. Roller capacity 850 lbs.	231547	\$2,477.00	0	\$0.00
D. Additional conveyor rollers	202786	\$79.00	0	\$0.00
E. 24" Discharge table	1009399	\$370.00	0	\$0.00
F. 18" Adjustable work stop - Requires item 1009399	224531	\$758.00	0	\$0.00
G. Band mist lubricator	214936	\$1,860.00	0	\$0.00
H. Work light	221545	\$304.00	0	\$0.00
I. Laser line generator	1010956	\$1,248.00	0	\$0.00
J. Flushing hose attachment	178639	\$183.00	0	\$0.00
K. Additional USB stick of manuals	299998	\$91.00	0	\$0.00
L. A Nationally Recognized Testing Laboratory (NRTL) is an independent third-part laboratory recognized by the United States Occupational Safety and Health Administration (OSHA) to test and certify products to applicable product safety standards.	NRTL	\$3,500.00	0	\$0.00
M. Four (4) hours installation and operator training	SVC CHARGE LABOR	\$600.00	0	\$0.00

DoALL Cut Above 10 Year Warranty Annual Investment	Warranty	\$840.00	0	\$0.00
DoALL Saw Blades and Coolant				
N. Starter Kit of Six Pack Blades Consist of 1 each Silencer Plus 3-4, 4-6, 5-8, 8-12 and StructurALL 4-6, 5-8	1200006	\$383.49	0	\$0.00
O. 5 Gal. Pail of Band All 102 Semi Synthetic	13410245	\$160.13	0	\$0.00
P. 5 Gal. Pail of AL-2000 Mist Coolant	21200045	\$239.68	0	\$0.00

Pricing	
Total Productivity Package Price	\$16,995.00
This proposal is issued subject to terms and conditions listed on the last page.	

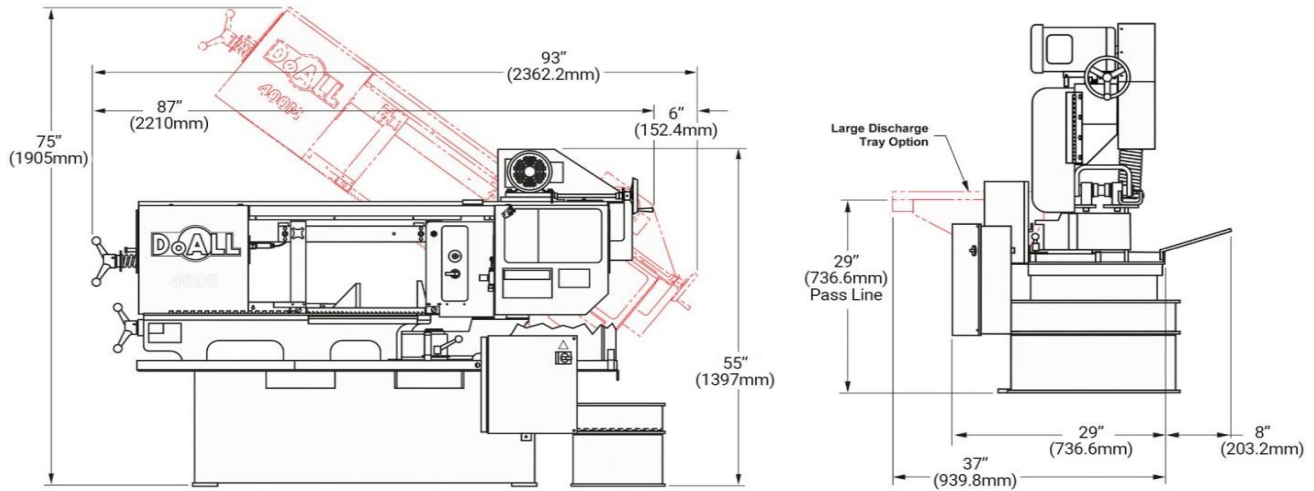

Dimensional Drawings of 400-S



Optional DoALL Cut Above 10 Year Warranty

- Annual Fee includes one preventative maintenance every year scheduled at the customers convenience.

Guarantee:

We guarantee your DoALL Saw will perform to stated specifications for 10 years, place the machine at depreciated replacement cost to the customer. If machine does fail, DSP will respond within 48 hours to investigate and design a tailored repair plan.

What's covered?

Parts and labor to repair any workmanship or material related defects. This will include items such as, band-wheels, transmission, motors, weldments, castings, electronic components, bearings (other than blade guide bearings), etc.

What's not covered?

Wear parts, which will include; blade guide bearings, band-wheel tires, band brushes, wear plates, coolant pumps, hydraulic cylinders, roller guides, any bearings, etc.

See your DoALL representative for details of this productivity enhancing program

For the FULL WARRANTY AGREEMENT visit:

<https://www.doallsaws.com/warranty>

Signed Customer Service Agreement Required

CONDITIONS GOVERNING QUOTATIONS

PRICES

All prices are F.O.B. factory dock, subject to change without notice and are exclusive of sales, use and other taxes. Proposed shipping schedule is estimated on information available at the date of this quotation and is subject to change.

WARRANTY

Any equipment or part thereof covered by this quotation which under normal operating conditions in the plant of the original purchaser proves defective in material or workmanship within one year from the date of shipment, as determined by our reasonable inspection, will at our option and expense, either be repaired or replaced. This warranty is conditioned on prompt notification to DoALL of any claim of defect and the establishment that the equipment has been properly maintained and operated within the limits of rated or normal usage. We expressly exclude from this warranty any liability whatsoever for loss of use or for indirect or consequential damages.

FOREGOING WARRANTY IS EXCLUSIVE AND IN LIEU OF OTHER WARRANTIES OF MERCHANTABILITY, FITNESS FOR A PARTICULAR PURPOSE AND OF ANY OTHER TYPE, WHETHER EXPRESSED OR IMPLIED.

THERE ARE NO WARRANTIES WHICH EXTEND BEYOND THE DESCRIPTION ON THE FACE HEREOF.

OSHA COMPLIANCE

DoALL Machine Tools meet all applicable requirements of the Williams-Steiger Occupational Safety and Health Act of 1970 in effect as of the date of this proposal, as in those requirements are interpreted by DoALL. Because actual compliance by employers is beyond our control, DoALL cannot warrant that the machines will comply in use.

Review all available options/accessories to enhance your sawing needs.

Please note safety labels and any interface requirements noted in this proposal including use proper Wye power, plant and equipment air pressure (80 psi), voltage, leveling, machine bolt/tie downs, safety fence devices and use of proper installation procedures (i.e. do not install within an area smaller than the listed space requirements).

SPECIFICATION

The specifications contained herein were in effect at the time of this quotation was approved for printing. They are subject to the right of the manufacturer whose policy is one of continuing improvement to change specifications of design at any time without notice and to make changes or improvements upon its products without assuming any obligation to install the same upon its products manufactured prior to the changed improvement.

CANCELLATION

Any order for standard items once placed with and accepted by us may be canceled only with our consent and then only upon payment to us, as liquidated damages, an amount equal to 20% of our sales price of all products covered by the order. An order for a special item may be subject to additional cancellation charges.

TERMS

To be determined by the seller – subject to credit approval. This proposal, constitutes our entire agreement regarding your requirements as we understand them. By acceptance of this proposal, you agree to operate the equipment in a safe manner, not to remove or alter any safety features of the equipment and indemnify and hold us harmless from any claim or liability resulting from your actions or the actions of your employees, with respect to the equipment. Copyright © 2022 DoALL Sawing Products. All Rights Reserved.

No image(s) or part(s) from this quote may be reproduced without the written permission of DoALL Sawing Products. Options, specifications, prices and quote contents are subject to change without notice or obligation.

Machine safety items may be omitted for illustration purposes only -- For proper application, always read the operation manual. Prices are subject to change at any time. Quotes are valid for 30 days from date listed.

WE APPRECIATE THIS OPPORTUNITY TO QUOTE AND INVITE YOUR ORDER.