

RICHARDS

Multiform

CATALOG 74A
MODEL MUB
FACTORY NO: MUB001
without tooling

HYDRAULIC UTILITY BENDER

THE MOST VERSATILE ALL PURPOSE UTILITY BENDER
AVAILABLE

OPERATES IN EITHER HORIZONTAL OR VERTICAL POSITION
FLAT BENDING • PIPE BENDING • ROD BENDING • U-BOLTS • REBAR •
BUSS BARS • TOOLING AVAILABLE FOR SPECIAL SHAPES AND DESIGNS

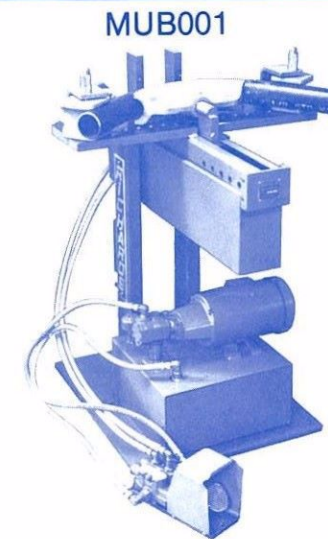

ELECTRIC MOTOR

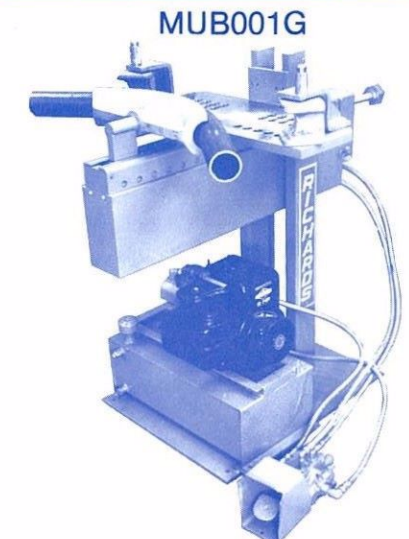

GASOLINE ENGINE

Patent pending
Any OSHA guarding requirements are the responsibility of the purchaser

CAPACITY	SPECIFICATIONS
1/2" x 4" mild steel 5/8" x 3" mild steel 3/4" x 2" mild steel 1-1/2" round mild steel 1-1/2" square mild steel 2" schedule 40 pipe 1/4" x 2" mild steel angles Notching: 1/4" x 2" angle mild steel 2" schedule 40 pipe Piercing: 1/2" holes, 1/4" mild steel Shearing: 1/4" x 4" mild steel Rod Parting: 1/2" mild steel	Ram travel: 12" Rating: 10 Tons Power: 2 HP, 220V-1 Phase, 220V-3 Phase 440V-3 Phase, (Specify) 5HP Gasoline Engine (optional) Faceplate: 12" x 30" Working Height: Horizontal 39" Vertical 36" Height: 42" (Horizontal) Width: 30" Depth: 42" Shipping Weight: 500 lbs.

© copyright 1982

J. A. RICHARDS COMPANY

903 N. Pitcher St., Kalamazoo, Michigan 49007
616/343-4684 • Toll Free 1-800-253-3288 • TWX 810-277-1020
Mich. 1-800-632-4162

Manufactured in U.S.A.

Printed in U.S.A.

RICHARDS

- DOVETAIL TOOLING AVAILABLE
- VARIABLE SPEED RAM
- RAM STROKE ADJUSTABLE
- ROTARY BENDER ATTACHMENT (Optional)
See catalog No. 75

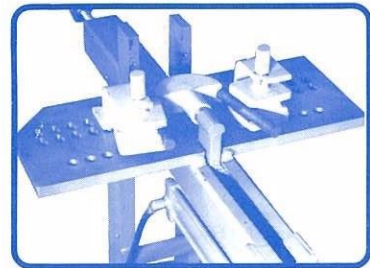

1" ROUND U BOLT



FLAT BENDING
1/2" x 4" hot roll

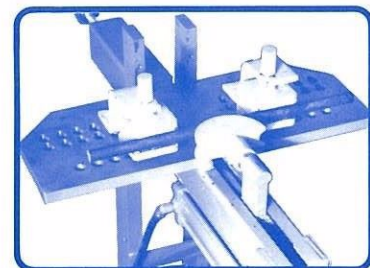

1" ROUND BENDING

HORIZONTAL MODE Forming 2" schedule 40 pipe

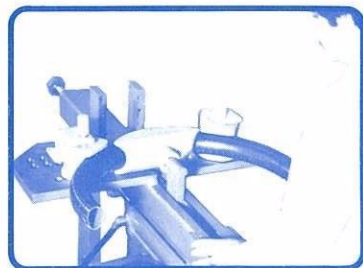
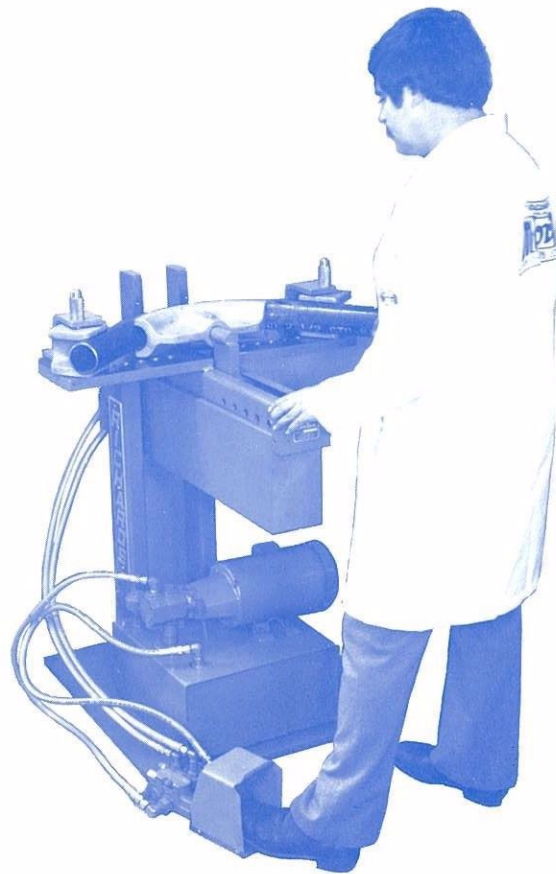

2" PIPE BENDING

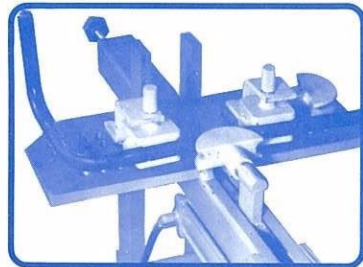

1-1/4" PIPE BENDING

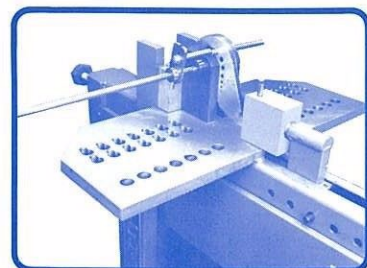

ROD PARTER
1/2" Mild Steel

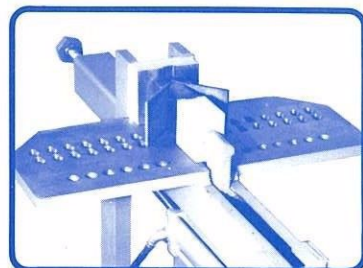

Dovetail Adapters with
Standard Tooling 1/4" x 4"
Hot Roll
(as used on our standard
benders)

RICHARDS

RICHARDS

Multiform

MODEL NO. RBA001

FACTORY NO. MUB080 FOR MUB
FACTORY NO. RBA002 FOR BBC
FACTORY NO. RBA003 FOR 44HB,
BBB & BBH
(patent pending)

ROTARY BENDING ATTACHMENT

FITS HYDRAULIC RAM BENDER MODELS:
MUB - 44HB - BBB - BBC - BBH

- BEND TUBING, ROUNDS, SQUARES AND FLATS EASILY AND QUICKLY WITH THIS UNIQUE AND EXCLUSIVE BENDING ATTACHMENT
- MOUNTS TO BENDER FACEPLATE (EASY TO INSTALL AND REMOVE)
- ECONOMICAL AND HIGHLY VERSATILE TOOLING AVAILABLE
- POPULAR SIZE TOOLING SETS AVAILABLE FROM INVENTORY

MUB080 ATTACHMENT SHOWN MOUNTED ON MUB UTILITY BENDER

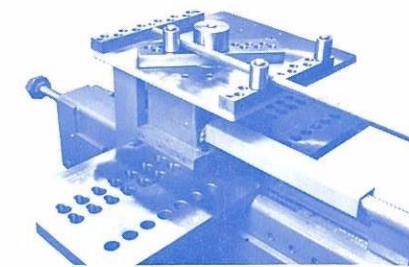

ROD BENDING

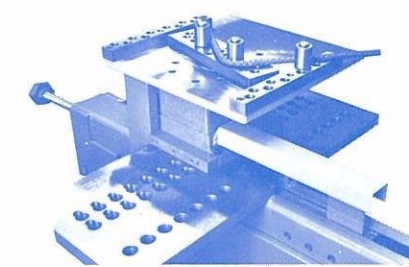

REBAR
DOUBLE BEND

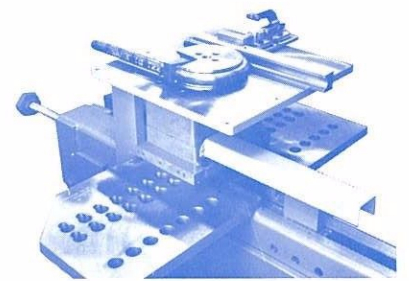

TUBE BENDING

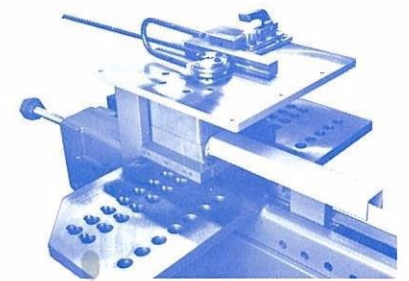
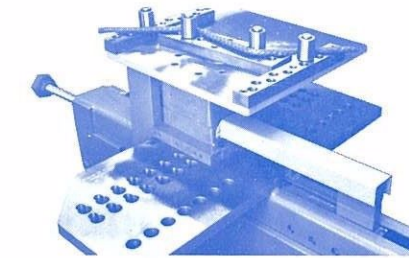
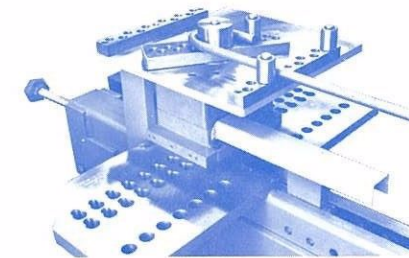

Any OSHA guarding requirements are the responsibility of the purchaser

CAPACITY	SPECIFICATIONS
1-1/4" 16 ga. Tubing	Maximum Radius: 6"
3/4" Round Mild Steel	Weight: 125 Lbs.
1/2" Square Mild Steel	Height: 7"
3/4" Rebar	Width: 20"
3/4" Schedule 40 Pipe	Depth: 20"
1/4" x 2" Mild Steel (flat)	
1/2" Round Mild Steel (Double Bend)	
1/4" x 1" Mild Steel (Edge)	

© copyright 1982

J. A. RICHARDS COMPANY

903 N. Pitcher St., Kalamazoo, Michigan 49007
616/343-4684 • Toll Free 1-800-253-3288 • TWX 810-277-1020

Manufactured in U.S.A.

Mich. 1-800-632-4162

Printed in U.S.A.

TOOLING SETS FOR TUBE BENDING

(Tooling set consists of form block with hook clamp and form bar)

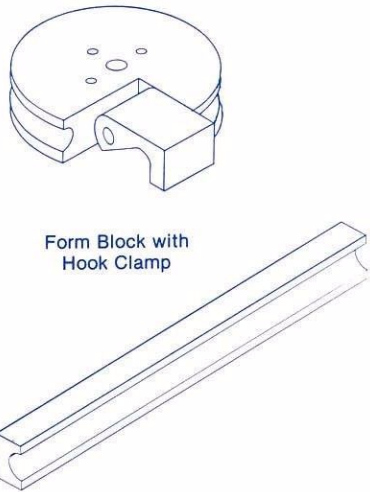

Form Block with Hook Clamp

Form Bar (Tube Bending Tooling sets for MUB080 Attachment also fit Models 3 & 3P Rotary Benders)

PART NO.	TUBING OD	RADIUS	NOMENCLATURE
RBA095	.250	.75CLR*	Tooling Set
RBA096	.312	.93CLR	Tooling Set
RBA097	.375	1.12CLR	Tooling Set
RBA098	.500	1.50CLR	Tooling Set
RBA099	.625	1.87CLR	Tooling Set
RBA100	.750	2.25CLR	Tooling Set
RBA101	.875	2.62CLR	Tooling Set
RBA102	1.000	3.00CLR	Tooling Set
RBA103	1.125	3.37CLR	Tooling Set
RBA104	1.250	3.75CLR	Tooling Set
RBA105	1.375	4.12CLR	Tooling Set
RBA106	1.500	4.50CLR	Tooling Set

* Center line radius

ACCESSORIES FOR TUBE BENDING

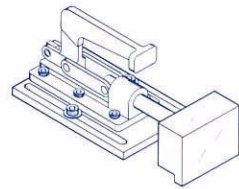

RBA112 Follow Bar Clamp (Flat)

Bar Clamp is required with first set of tooling

RADIUS FORM BLOCKS FOR BENDING RODS, SQUARES, FLATS OR REBAR

(RBA110 Bend Set Required) (Roller Bend Pins Required)

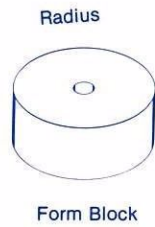

Radius

Form Block

PART NO.	RADIUS	PART NO.	RADIUS	PART NO.	RADIUS
RBA114	1"	RBA121	2-3/4"	RBA128	4-1/2"
RBA115	1-1/4"	RBA122	3"	RBA129	4-3/4"
RBA116	1-1/2"	RBA123	3-1/4"	RBA130	5"
RBA117	1-3/4"	RBA124	3-1/2"	RBA131	5-1/4"
RBA118	2"	RBA125	3-3/4"	RBA132	5-1/2"
RBA119	2-1/4"	RBA126	4"	RBA133	5-3/4"
RBA120	2-1/2"	RBA127	4-1/4"	RBA134	6"

ACCESSORIES FOR BENDING RODS, SQUARES, FLATS OR REBAR

Bend Set consists of two Bend Bars and one Swing Arm

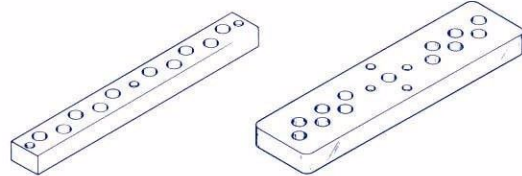

Bend Bar (2) Bend Set

Swing Arm (1) RBA110



RBA094 Roller Bend Pin

Note: Two to five roller bend pins required with first Bend Set (number depends on type of bend required)

J. A. Richards Company provides engineering and fabrication service for special tooling designs for all cataloged models. Designs and specifications subject to change without notice.

- FUNCTIONS AS ARBOR PRESS
- PIERCING, SHEARING, NOTCHING AND ROD PARTING ATTACHMENTS (Optional)
- SENSAMATIC CONTROL VALVE
- DEADMAN CONTROL

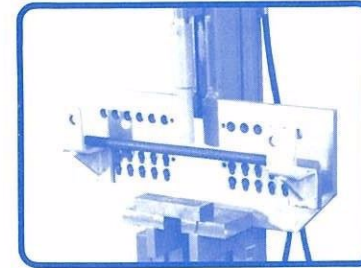

VERTICAL MODE STRAIGHTENING PRESS Flat or round, etc.

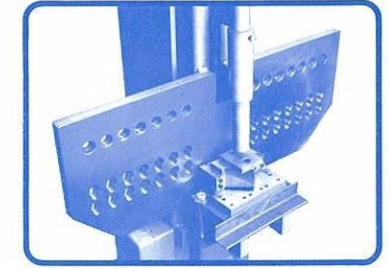

NOTCHING Angle iron and sheets

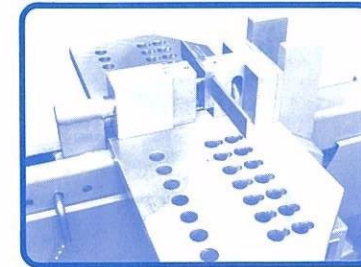
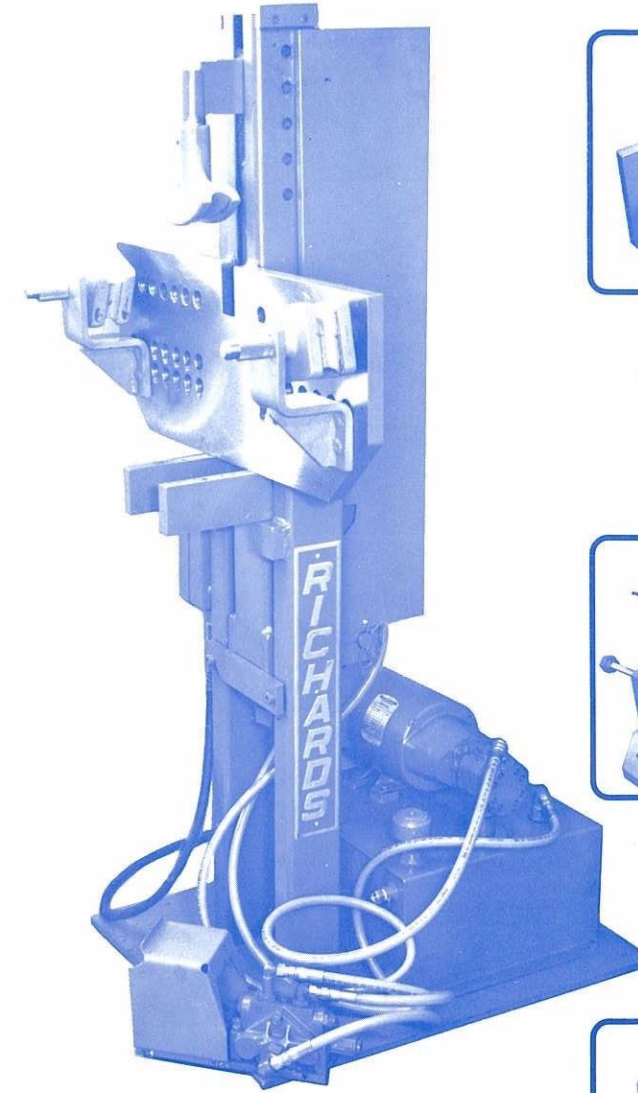

PIERCING 1/2" x 1/4"

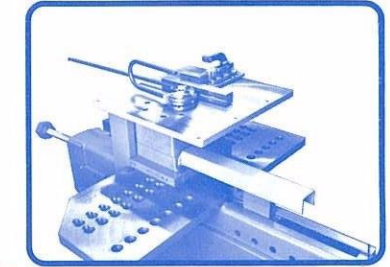

ROTARY BENDING ATTACHMENT (See catalog No. 75)

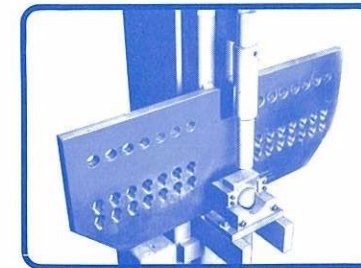

TUBING NOTCHING

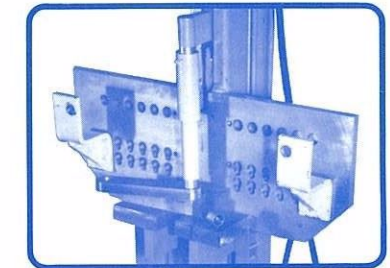

VERTICAL MODE ARBOR PRESS - BUSHINGS, etc.

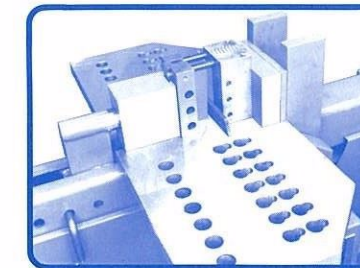

SHEARING DIE

VERTICAL MODE

TOOLING FOR PIPE AND ROD

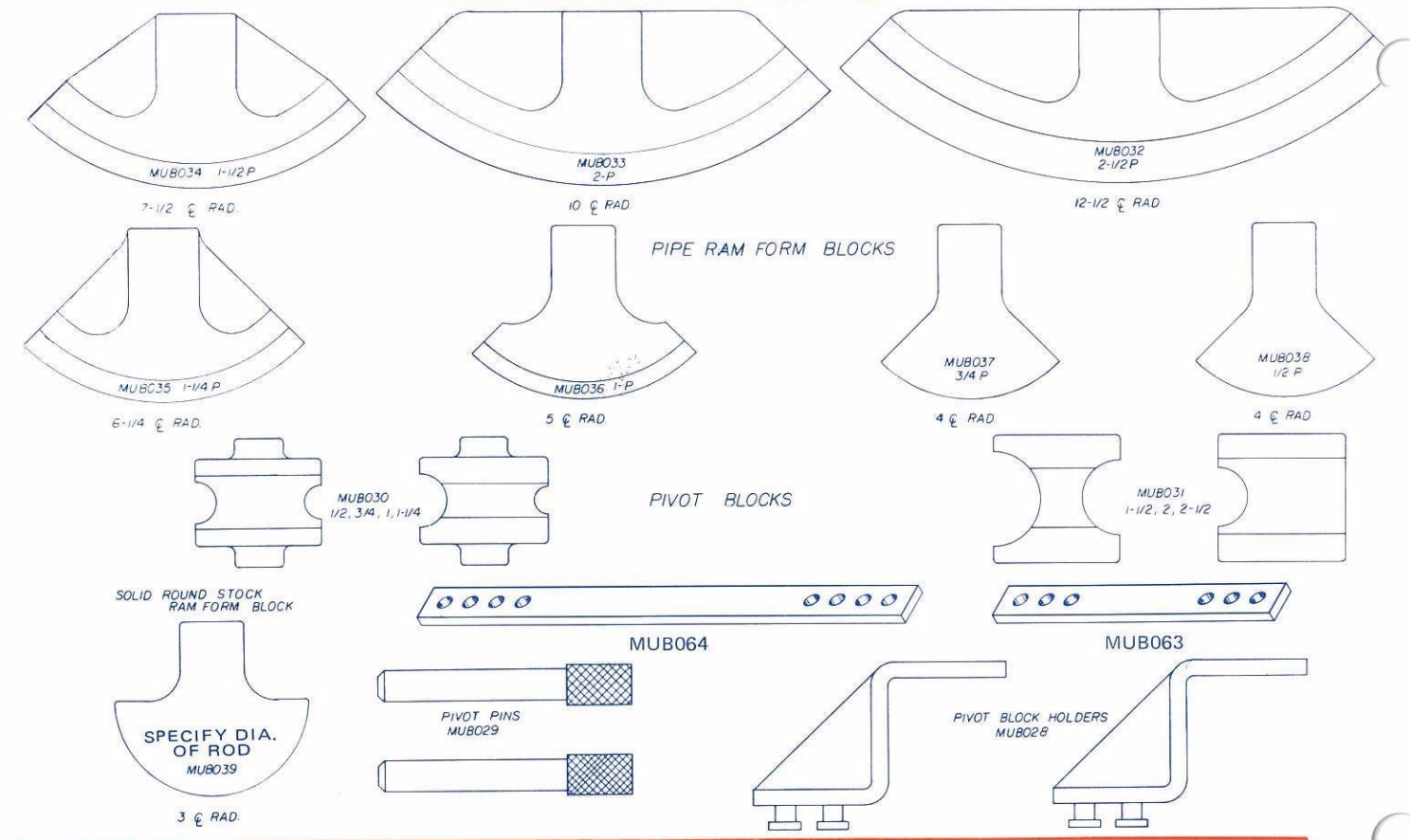

TOOLING FOR FLATS, ANGLES AND SQUARES

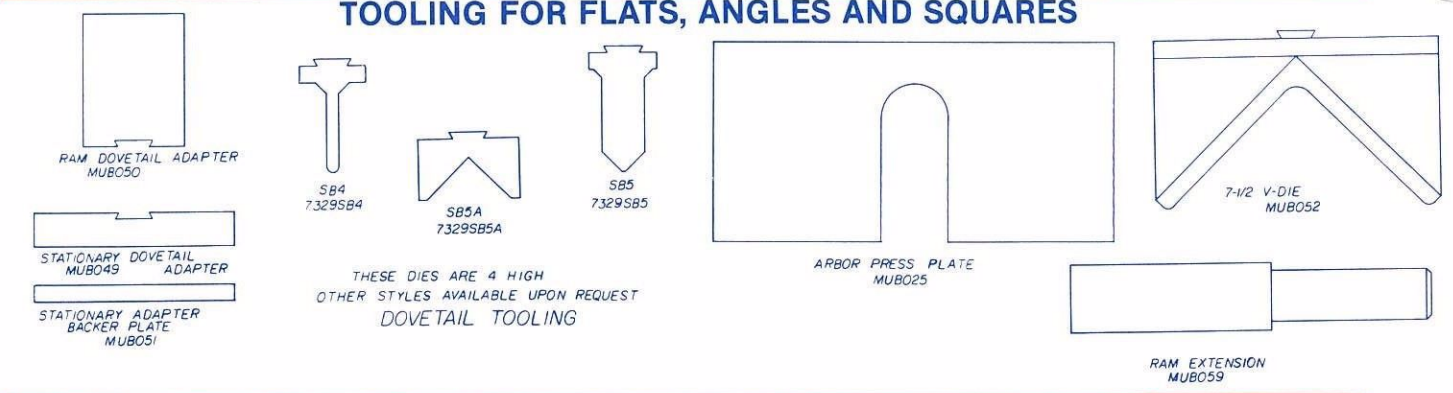

ACCESSORIES

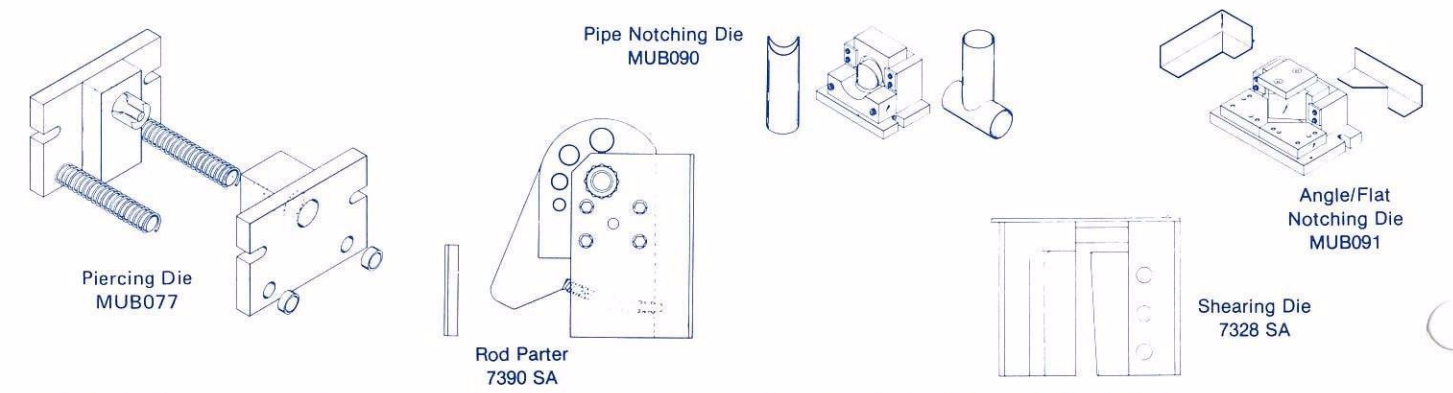

J. A. Richards Company provides engineering and fabrication service for special tooling designs for all cataloged models. Designs and specifications subject to change without notice.

BENDING GATE FRAME FOR LIVE STOCK PEN

Bending gate frame for live stock pen on the Utility Bender to form 7" inside radius with 18" between the legs. Material is 1" square 12 gauge tubing.

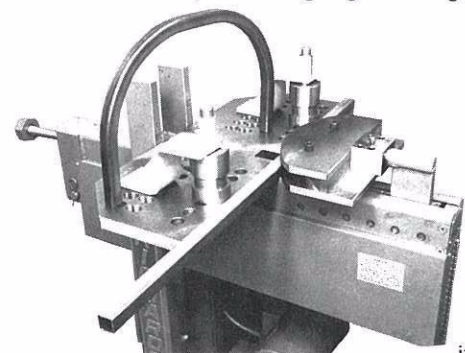

item 1

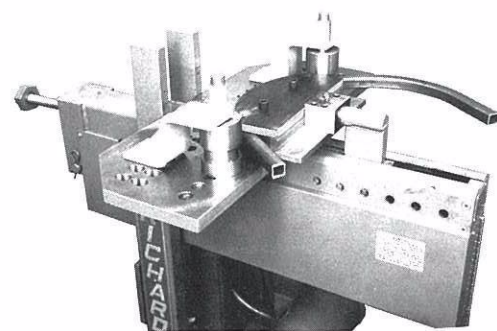

item 2

WING DIE TOOLING IS USED TO BEND 1-1/2 HR U-BOLTS

Wing die tooling used to bend 1-1/2" hot rolled "U" bolts.

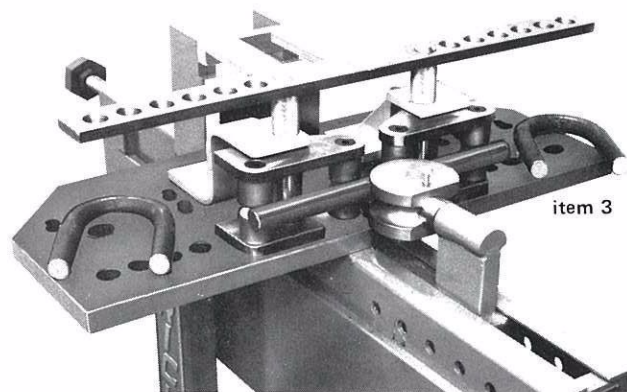

item 3

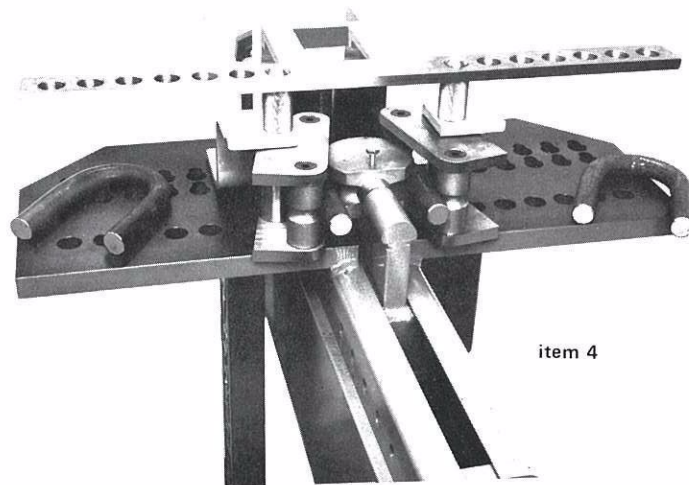

item 4

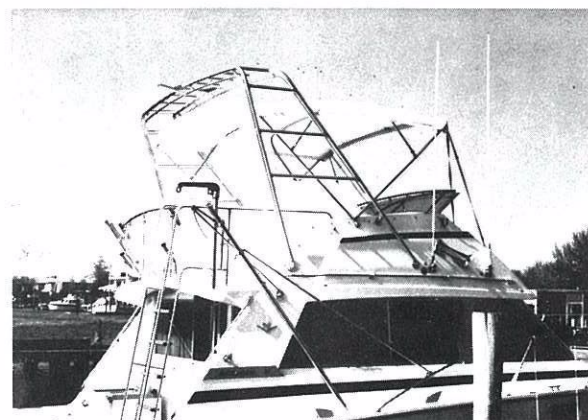

item 5

Marine radar tower and canopy made on the Utility Bender.

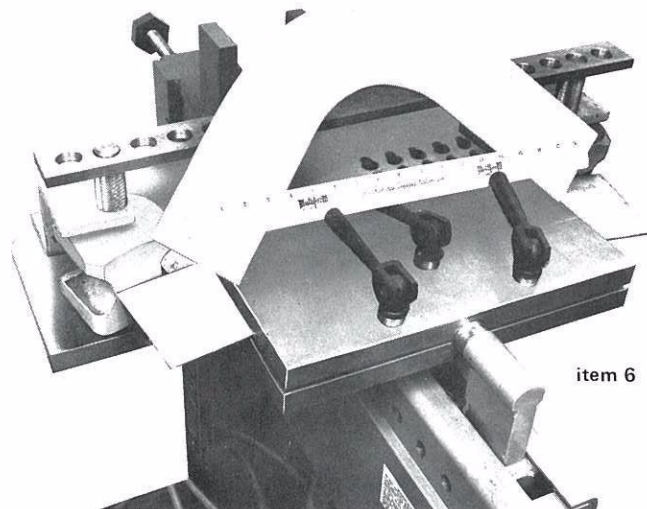

item 6

Edge bending 1/4 x 4 copper.

BENDING HANDLE BAR FOR EXERCISE MACHINE

Bending handle bar for exercise machine. Forming of the 6" radius on the rotary tooling attachment. Forming the large radius in three hits, using ligniform tooling material for the punch section is shown in illustration 1.

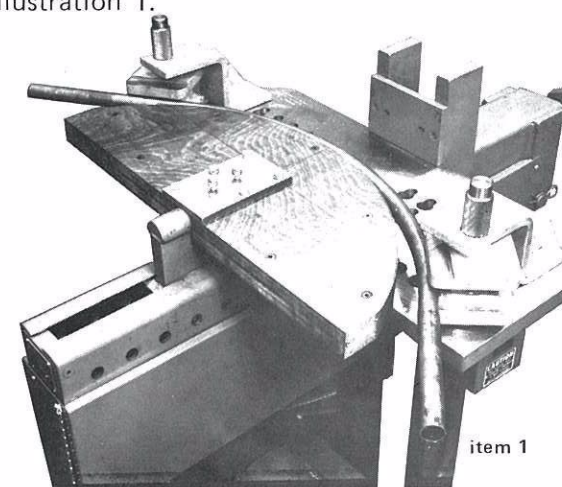

item 1

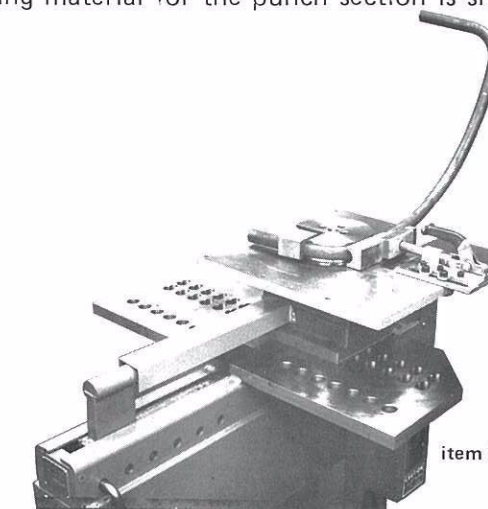

item 2

ROTARY BENDING ATTACHMENT FOR HYDRAULIC RAM BENDERS

Rotary bending attachment for hydraulic or pneumatic ram benders with particular applications as shown for the Utility Bender with a longer stroke.

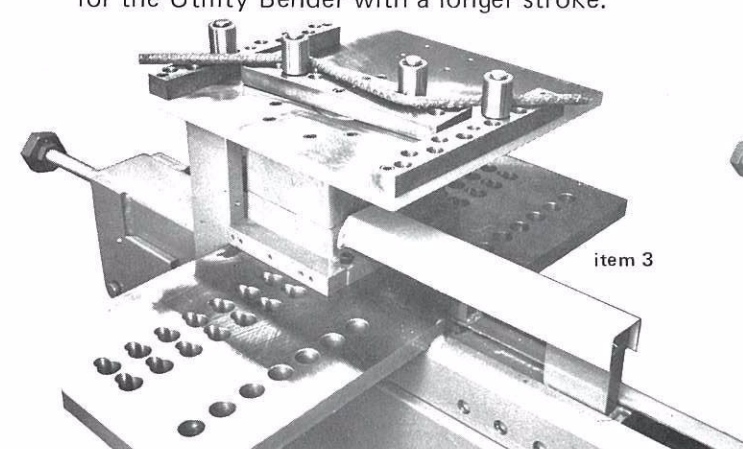

item 3

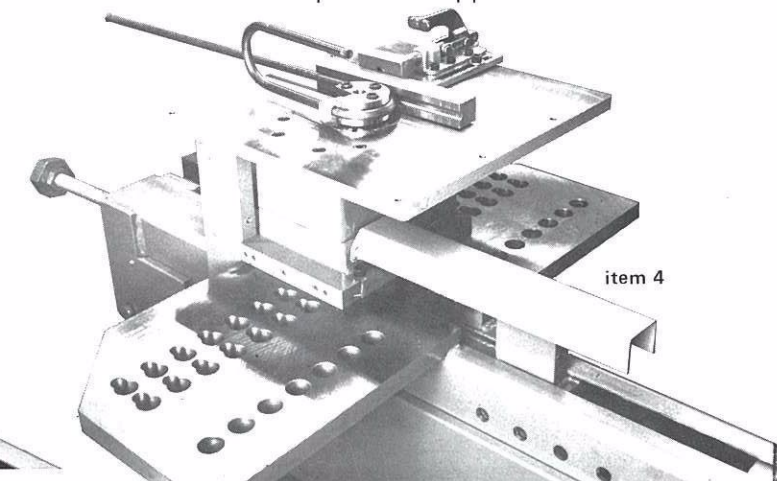

item 4

BENDING SQUARE TUBING WITH RAM TYPE BENDERS

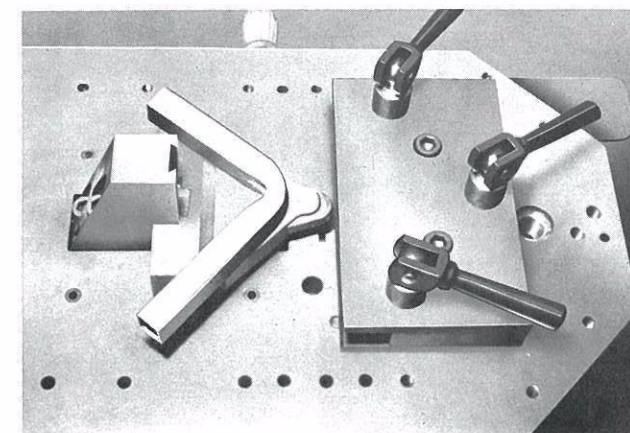

item 5

Crush bending 1-1/4" square 16 gauge stainless on a 44HB or BBB Model Bender.

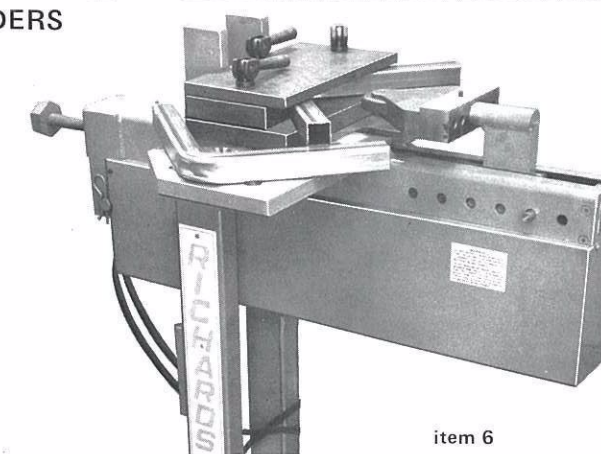

item 6

Crush bend tooling used on the Utility Bender for large diameter radius. Crush bend forming of guard rails for livestock pen applications.