

NEXIA SERIES

280~1300 Ton (small, medium tonnage)

Feature

- Injection Molding Machine : 280~1300Ton
- Servo Motor Axis : Max. 7 axis
- Motion Guide : High Strength and Low noise LM
- Crosswise Frame : Double Support Type
- Vertical Arm Structure : Telescopic Arm(2 step)
- Controller : Body Attached Controller
- All Axis : Digital Servo Motor

Power : 1Phase/3Phase AC220V(50/60Hz)
 Driving Method : Digital Servo Motor
 Control Method : Micro Computer
 Air Pressure : 6 kgf/cm²
 Max. Air Pressure : 8 kgf/cm²
 Chuck Rotation : 90°

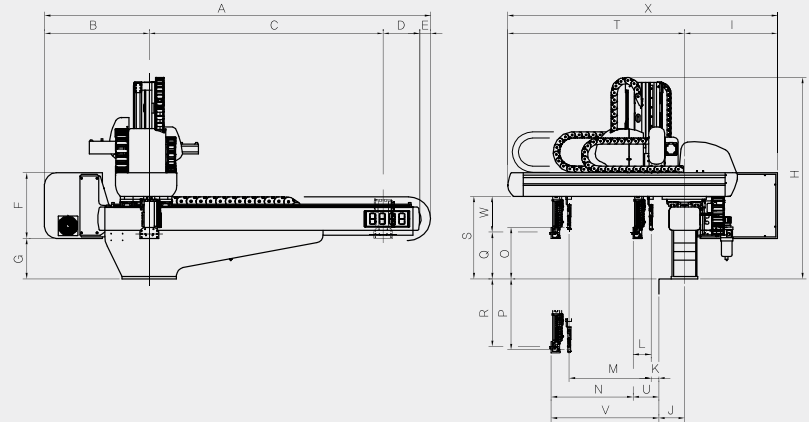

Technical Specification

Model	Traverse (mm)			Vertical (mm)		Crosswise (mm)		Max. Electric Consumption	Air Consumption [l (normal)/Cycle]	Max. Payload (Chuck Included)	I.M.M (Ton)
	Standard	L-Type	LL-Type	Main Arm	Sub Arm	Main Arm	Sub Arm				
NEXIA-400S	1700	2000	-	1100 (1300)	-	935	-	1Phase / AC 220V S: 11.6A / D: 15.7A	7	8 Kgf	280~450
NEXIA-400D				1100 (1300)	800	800					
NEXIA-600S	2000	2500	-	1300 (1600)	-	1110	-	1Phase / AC 220V S: 11.6A / D: 15.7A	16	12 Kgf	400~650
NEXIA-600D				1300 (1600)	905	905					
NEXIA-800S	2500	3000	-	1600	-	1150	-	1Phase / AC 220V S: 11.6A / D: 15.7A	22	18 Kgf	550~900
NEXIA-800D				1600	940	940					
NEXIA-1300S	3000	3500	-	1800	-	1585	-	3Phase / AC 220V S: 8.5A / D: 10.8A	35	25 Kgf	1000~1300
NEXIA-1300D				1800	1370	1370					

All information subject to change without notice for quality improvements.

Dimension

Unit : mm / () mark signify L Type.

Model	A	B	C	D	E	F	G	H	I	J	K	L	M	N	O	P	Q	R	S	T	U	V	W	X
NEXIA-400S	2759 (3059)	760	1700 (2000)	285	14	400	280	1480	556	185	-	-	-	935	-	-	138	962	530	1435	32	967	392	1991
NEXIA-400D											42	125	800	800	210	890					167			
NEXIA-600S	3100 (3600)	785	2000 (2500)	315	-	400	314	1798	580	205	-	-	-	1110	-	-	178	1122	632	1686	51	1161	454	2266
NEXIA-600D											89	168	905	905	225	1075					256			
NEXIA-800S	3585 (4085)	770	2500 (3000)	315	-	400	444	2071	606	235	-	-	-	1150	-	-	199	1401	753	1779	98	1248	554	2385
NEXIA-800D											72	237	940	940	249	1351					308			
NEXIA-1300S	4295 (4795)	915	3000 (3500)	380	-	400	565	2466	631	255	-	-	-	1585	-	-	179	1621	927	2293	122	1707	748	2924
NEXIA-1300D											76	261	1370	1370	264	1536					337			

All information subject to change without notice for quality improvements.