

Coil Lifters and Upenders

Model 88 - Heavy Duty Coil Upender



Shown with V-Block Option

PRODUCT FEATURES:

- Fast and convenient way to upend coils to 90°.
- 240 or 480 operating voltage (specify).
- Heavy duty disc brake will stop load in any position.
- Reversing magnetic starter with pendant control and 10' cord.
- Stop travel/over travel limit switches.

PRODUCT OPTIONS:

- Larger platforms available.
- V-Block, either standard or urethane faced.
(Provide coil information. Height set to accommodate a 4" pallet unless otherwise specified.)
- 180° horizontal rotation which permits loading and unloading from same side.
- Lift truck fork pockets.

NOTE: Additional data may be required to properly size the drive system. Load information including dimensions and center of gravity should be provided.

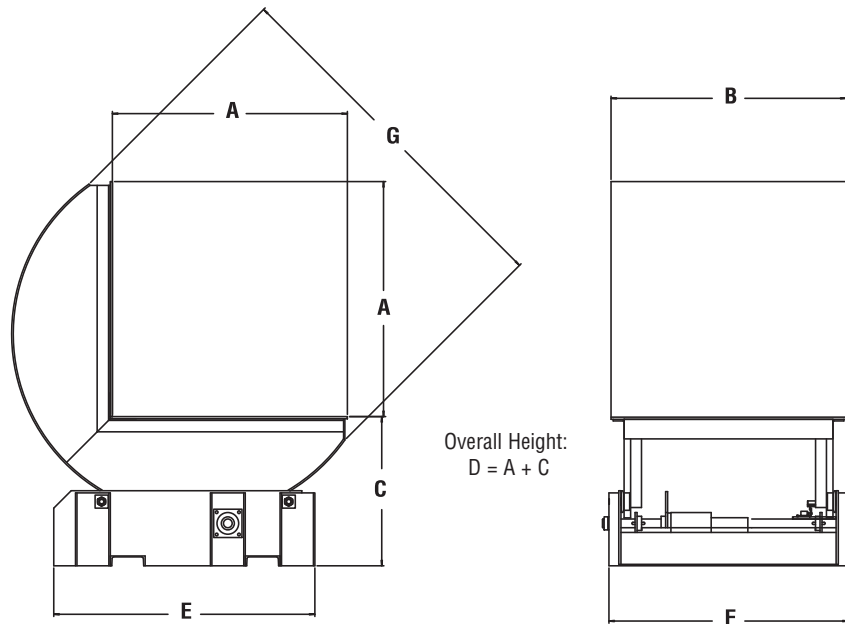

SPECIFICATIONS

Model Number	Capacity (tons)	Dimensions (inches)							Weight (lbs.)
		A*	B	C	Overall Height D	E	F	G	
88-1-36	1	36	36	24	60	48	36	51	1500
88-2-36	2	36	36	24	60	48	36	51	1600
88-3-42	3	42	42	24	66	56	42	60	2000
88-4-42	4	42	42	24	66	56	42	60	2200
88-5-48	5	48	48	30	78	61	48	66	2750
88-7 1/2-48	7-1/2	48	48	30	78	61	48	66	2900
88-10-54	10	54	54	30	84	60	55	74	3700
88-12 1/2-54	12-1/2	54	54	36	90	69	55	74	4000
88-15-60	15	60	60	36	96	73	60	80	4500
88-20-60	20	60	60	36	96	73	60	80	6200
88-25-72	25	72	72	43	115	88	72	96	10000
88-30-72	30	72	72	48	120	88	72	96	12000

*Coil center of gravity must be 1/2 of 'A'. If different please specify coil or load information.

Pallets must not extend over platform sides.

Other sizes available, consult factory.