

CRANE CAPACITY	15 TONS
TROLLEY TYPE	EZBP
HOIST TYPE	P600H26L4/1F10
CRANE TRAVEL SPEED	100/25 FPM 2x 1.29/ .32 HP
TROLLEY TRAVEL SPEED	80/20 FPM 1x 1.29/ .32 HP
HOIST LIFTING SPEED	16/1.6 FPM 20/2.3 HP
ENDTRUCK TYPE	KTL-8Z 400/4000
WHEEL LOAD	R = 19157 LB
RUNWAY BEAM	60 LB
RAIL SIZE (ASCE)	N=W16X50 S=W30X99
LENGTH OF RUNWAY	440 FT
RUNWAY ELECTRIFICATION	460/3/60
SERVICE	INDOOR
BOX GIRDER (1) WT.	5071 LB
ENDTRUCK (2) WT.	4100 LB
TROLLEY (1) WT.	4000 LB
SHIPPING WT.	18142 LB

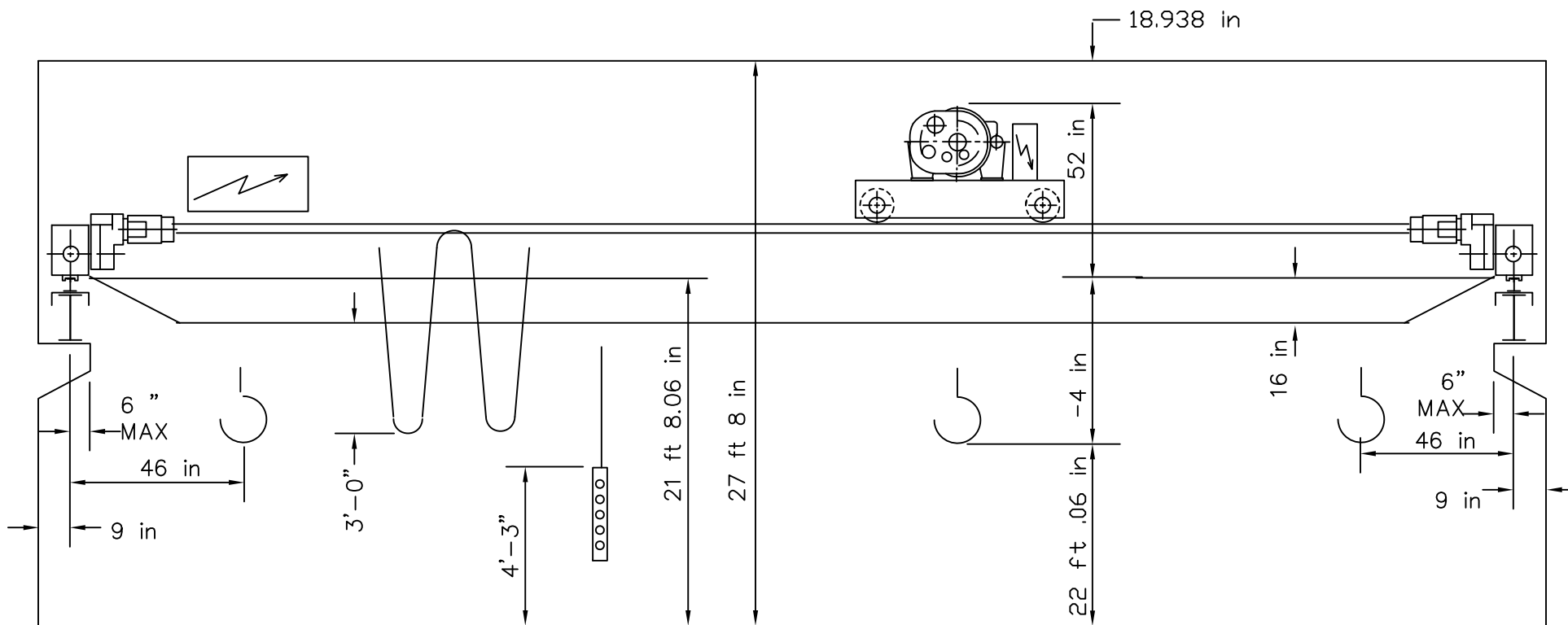

REMARKS: ULS-1 OVERLOAD DEVICE

CUSTOMER GRAND RAPIDS MATL HDLG 5015 52ND ST. S.E. GRAND RAPIDS, MI 49508	APPROVED
JOB NO. 640481	SERIAL NO. 85203

1985

10-03 DHR

DOUBLE GIRDER CRANE

21321049